

▶ **The Bronx High School of Science**

▶ **The Brooklyn Latin School**

▶ **Brooklyn Technical High School**

▶ **High School for Mathematics, Science and Engineering at the City College**

▶ **High School of American Studies at Lehman College**

▶ **Queens High School for the Sciences at York College**

▶ **Staten Island Technical High School**

▶ **Stuyvesant High School**

▶ **Fiorello H. LaGuardia High School of Music & Art and Performing Arts**

# SPECIALIZED HIGH SCHOOLS STUDENT HANDBOOK

## 2011 – 2012

FOR TRANSLATED VERSIONS OF THIS HANDBOOK, PLEASE SEE YOUR GUIDANCE COUNSELOR.		
للحصول على نسخ مترجمة من هذا الدليل، المرجو التحدث إلى استشاري التوجيه بمدرستكم.	POUR OBTENIR DES VERSIONS TRADUITES DE CE GUIDE, VEUILLEZ CONTACTER VOTRE CONSEILLER D'ÉDUCATION (GUIDANCE COUNSELOR).	ЗА ПЕРЕВОДОМ ОБРАЩАЙТЕСЬ К ШКОЛЬНОМУ КОНСУЛЬТАНТУ.
এই হ্যান্ডবুকের অনূদিত সংস্করণের জন্য অনুগ্রহপূর্বক আপনার গাইডেন্স কাউন্সিলরের সাথে দেখা করুন।	POU JWENN MANYÈL SA A NAN YON LÒT LANG, TANPRI, WÈ AVÈK KONSEYE PEDAGOJIK OU.	SI NECESITA VERSIONES TRADUCIDAS DE ESTE MANUAL, POR FAVOR COMUNÍQUESE CON SU CONSEJERO(A) VOCACIONAL.
如果您需要翻譯成中文的手冊， 請向您的輔導員詢問。	이 핸드북의 번역본을 원하시면, 가이던스 카운슬러에게 문의하십시오.	اس کتابچے کی ترجمہ شدہ نقل کے لیے برائے مہربانی اپنے رہنما مشیر سے رابطہ کریں۔

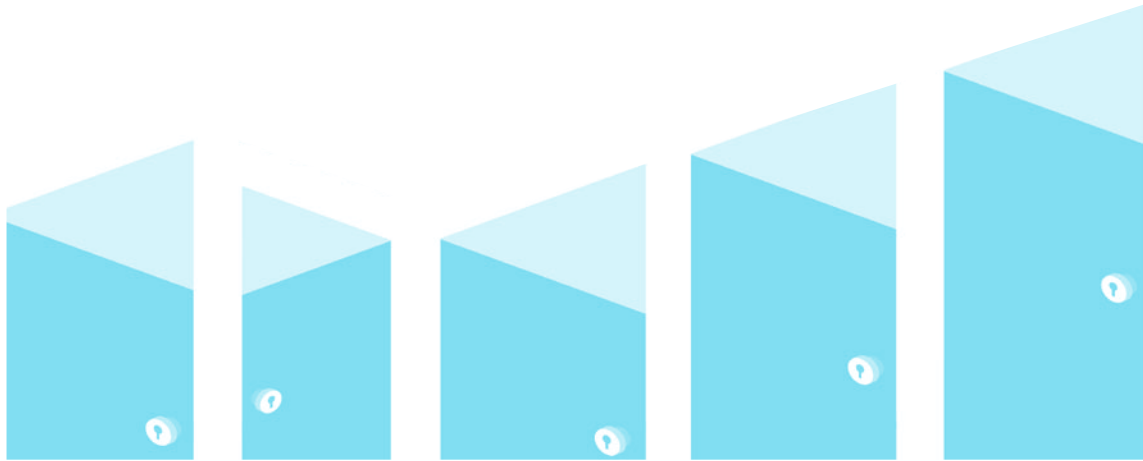

It is the policy of the Department of Education of the City of New York not to discriminate on the basis of race, color, religion, national origin, citizenship/immigration status, age, disability, marital status, sex, sexual orientation or gender identity/expression in its educational programs and activities, and to maintain an environment free of sexual harassment, as required by law. Inquiries regarding compliance with appropriate laws may be directed to: Director, Office of Equal Opportunity, 65 Court Street, Room 923, Brooklyn, New York 11201, Telephone 718-935-3320.

Cover artwork by Leo Mancini, student at Townsend Harris High School. Sample test items are taken from materials copyright © 1983-2011, NCS Pearson, Inc., 5601 Green Valley Drive, Bloomington, MN 55437.

<b>Message to Students and Parents/Guardians</b> .....	4
<b>▶ Section 1: The Specialized High Schools</b>	
The Bronx High School of Science .....	5
The Brooklyn Latin School .....	5
Brooklyn Technical High School .....	6
High School for Mathematics, Science and Engineering at the City College .....	6
High School of American Studies at Lehman College .....	6
Queens High School for the Sciences at York College .....	7
Staten Island Technical High School .....	7
Stuyvesant High School .....	8
Fiorello H. LaGuardia High School of Music & Art and Performing Arts .....	8
<b>▶ Section 2: Dates and Locations</b>	
Specialized High Schools Admissions Test (SHSAT) Dates and Locations .....	9
Fiorello H. LaGuardia High School of Music & Art and Performing Arts Admissions Process .....	10
Fiorello H. LaGuardia High School of Music & Art and Performing Arts Audition Information .....	10
Fiorello H. LaGuardia High School of Music & Art and Performing Arts Audition Dates .....	11
<b>▶ Section 3: Specialized High Schools Application Process</b>	
Steps in the Application Process .....	12
SHSAT Testing Procedures .....	12
Auditioning for Fiorello H. LaGuardia High School of Music & Art and Performing Arts .....	13
Notification Information .....	13
Admissions Process, Specialized High Schools Admissions Test .....	13
Additional SHSAT Information .....	13
Alternate Test Dates .....	13
Special Needs Students .....	13
<b>▶ Section 4: Test Description &amp; Materials</b>	
Test Materials .....	14
Filling in the Answer Sheet .....	14
SHSAT Scoring, Reporting, and Review Procedures .....	16
Discovery Program .....	17
<b>▶ Section 5: SHSAT Useful Tips for Testing</b>	
Before Test Day .....	18
Day of the Test .....	19
Specific Strategies: Verbal .....	20
Specific Strategies: Mathematics .....	26
<b>SAMPLE SHSAT TESTS</b>	
General Directions .....	28
Sample Answer Sheet, Form A .....	30
Sample Test, Form A .....	32
Sample Test, Form A, Explanations of Correct Answers .....	56
Sample Answer Sheet, Form B .....	69
Sample Test, Form B .....	70
Sample Test, Form B, Explanations of Correct Answers .....	94
Sample Math Problems for Grade 9 Students .....	109



## ► Message to Students and Parents/Guardians About Specialized High Schools Admissions

**T**he *Specialized High Schools Student Handbook 2011-2012* describes the programs and admissions procedures for the Specialized High Schools in New York City, which are: Fiorello H. LaGuardia High School of Music & Art and Performing Arts, The Bronx High School of Science, The Brooklyn Latin School, Brooklyn Technical High School, High School for Mathematics, Science and Engineering at the City College, High School of American Studies at Lehman College, Queens High School for the Sciences at York College, Staten Island Technical High School, and Stuyvesant High School. These schools were established under New York State Law 2590 – Section G. Each school provides students with a unique opportunity to pursue special interests and to develop their talents. Entrance into these schools is by examination except for Fiorello H. LaGuardia High School of Music & Art and Performing Arts (LaGuardia High School) which is based on a competitive audition and review of academic records. **Students must be residents of New York City in order to apply, register, and sit for the Specialized High Schools Admissions Test (SHSAT) and to audition for LaGuardia High School.** You should meet with your guidance counselor to discuss registration for the SHSAT or audition requirements.

In this handbook, you will find useful information about the Specialized High Schools, including programs in the schools, admission procedures, sample tests with test-taking tips, and a calendar of important dates. This handbook can be used by students and parents/guardians. Included in this handbook are two complete sample tests of the SHSAT, along with answers and explanations to help you prepare for the actual test. It is important to familiarize yourself with the information contained in this handbook.

The *Specialized High Schools Student Handbook* is a project of the New York City Department of Education, the Office of Assessment and the Division of Portfolio Planning.

For more information on other New York City Public High Schools, please see a copy of the *Directory of the New York City Public High Schools* or you may find it online at [www.nyc.gov/schools/ChoicesEnrollment/High](http://www.nyc.gov/schools/ChoicesEnrollment/High).



There are nine Specialized High Schools in New York City. For eight of these schools, admission is based solely on the score attained on the Specialized High Schools Admissions Test (SHSAT). For Fiorello H. LaGuardia High School of Music & Art and Performing Arts (LaGuardia High School), acceptance is based on an audition and a review of a student's academic records. Approximately 30,000 students took the SHSAT and almost 11,000 students applied to LaGuardia High School for September 2011 admission. General descriptions of the Specialized High Schools can be found in the *Directory of the New York City Public High Schools* (online at [www.nyc.gov/schools/ChoicesEnrollment/High](http://www.nyc.gov/schools/ChoicesEnrollment/High)). More information about each Specialized High School can be found below:

### ► The Bronx High School of Science

**75 West 205th Street, Bronx, New York 10468**

**Telephone:** (718) 817-7700 • **Website:** [www.bxscience.edu](http://www.bxscience.edu)

The Bronx High School of Science is a world-renowned college preparatory school for students gifted in science and mathematics. The school provides an enriched and diverse program to prepare students to enter the country's top colleges and universities, and to become leaders in all academic fields including science, business, medicine, and technology. The school offers a large variety of elective courses allowing students to explore areas of interest. All graduates attend college, and our goal from day one is to prepare students to attend the school of their dreams. The school boasts seven Nobel Laureates, more than any other high school and more than most countries. The school is the nation's all-time leader in the Westinghouse/Intel Science Talent Search, the leading science competition in the country.

The Bronx High School of Science offers every possible Advanced Placement course, except for German. The school offers nine foreign languages, numerous electives in biology, chemistry, physics, mathematics, technology, and the humanities. Bronx Science has an orchestra, band, chorus, jazz ensembles, and computerized music for students interested in music.

Extracurricular activities include over 60 after-school clubs, 30 athletic teams, an internationally acclaimed Speech and Debate Team, Mock Trial, a world-class Robotics Team, two theatrical productions each year, an award-winning yearbook, and scholarly journals. As our alumni uniformly agree: "Bronx Science—The Effect is Transformational."

For September 2011 admission, 19,587 students listed Bronx Science as a choice on their application and 1,044 offers were made.

### ► The Brooklyn Latin School

**325 Bushwick Avenue, Brooklyn, New York 11206**

**Telephone:** (718) 366-0154 • **Website:** [www.brooklynlatin.org](http://www.brooklynlatin.org)

The Brooklyn Latin School (TBLS) offers a classical liberal arts curriculum with an emphasis on the classics and Latin language instruction. Instruction emphasizes a core knowledge of the liberal arts that students will use as the basis for further, more detailed exploration. All students are required to complete four years of Latin, history, mathematics, English, science, and at least two years of a world language. In humanities classes, students participate in Socratic Seminars and declamation (public speaking exercises). Non-humanities classes feature labs, math interviews, and other inquiry-based methods. In all classes, students can expect a strong and continuing emphasis on structured writing and public speaking, as well as the overarching practice of analytical thinking that will ensure that all TBLS students are prepared for the rigors of college work.

The Brooklyn Latin School offers the prestigious International Baccalaureate (IB) Diploma Programme. Widely regarded around the world as the most rigorous and comprehensive course of study at the high school level, the IB Programme is a crucial aspect of the TBLS experience. Its emphasis on student-led inquiry, global perspectives and personal integrity conform perfectly with the ideals on which The Brooklyn Latin School was founded. In addition to rigorous class work, IB stresses independent thinking and community engagement. All students are expected to complete an extended essay, a lengthy independent essay on a subject of their choosing, the completion of which correlates closely to college-level research writing. In addition, students are required to engage in a total of 150 hours of creativity, action, and service (CAS), which may include volunteering or engaging meaningfully with the community outside TBLS. We believe that both of these requirements will help our students become well-rounded citizens of the world.

For September 2011 admission, 14,529 students listed The Brooklyn Latin School as a choice on their application and 572 offers were made.

## ► Brooklyn Technical High School

**29 Fort Greene Place, Brooklyn, New York 11217**

**Telephone:** (718) 804-6400 • **Website:** [www.bths.edu](http://www.bths.edu)

Brooklyn Technical High School (Brooklyn Tech) is committed to providing an outstanding educational experience in the areas of engineering, the sciences, and computer science for its student body.

During the ninth and tenth grades, all students take an academic core and begin to explore the fields of engineering, science, and computers through hands-on experience in fully equipped laboratories, computer centers, shops, and theory classes. A select group of applicants may also choose to enroll in our Gateway to Medicine pre-medical program. Gateway is a four-year small learning community focused on careers in the medical professions.

For the eleventh and twelfth grades, Brooklyn Tech students choose one of the following major areas of concentration: Aerospace Engineering, Architecture, Bio-Medical Engineering, Biological Science, Chemistry, Civil Engineering, College Prep, Computer Science, Electro-Mechanical Engineering, Environmental Science, Industrial Design, Law & Society, Mathematics, Media & Graphic Arts, and Social Science.

While specializing in these areas, students continue their academic core. It is important to note that Brooklyn Tech students meet the requirements to enter any field of study on the college level, regardless of their major. However, they are particularly well prepared in their major area of concentration.

For September 2011 admission, 23,085 students listed Brooklyn Tech as a choice on their application and 1,951 offers were made.

## ► High School for Mathematics, Science and Engineering at the City College

**240 Convent Avenue, New York, New York 10031**

**Telephone:** (212) 281-6490 • **Website:** [www.hsmse.org](http://www.hsmse.org)

The High School for Mathematics, Science and Engineering at the City College provides an educational experience in which students are challenged to expand their intellect and to develop habits of inquiry, expression, critical thinking, and problem seeking, as well as problem solving, research, and presentation. The high school's challenging instructional program focuses on mathematics, science, and engineering.

The curriculum encompasses core courses and advanced studies including writing and composition, history, literature, language, mathematics, science, engineering, and the arts. The courses are integrated with collegiate experiences throughout the core and elective courses, including a variety of summer institutes related to individualized student interests. Additional enrichment opportunities include school publications and academic competitions, such as Math Team and Robotics.

For September 2011 admission, 18,741 students listed High School for Mathematics, Science and Engineering at the City College as a choice on their application and 228 offers were made.

## ► High School of American Studies at Lehman College

**2925 Goulden Avenue, Bronx, New York 10468**

**Telephone:** (718) 329-2144 • **Website:** [www.hsas-lehman.org](http://www.hsas-lehman.org)

The High School of American Studies at Lehman College emphasizes the study of American History and offers students an academic program that is both well-rounded and challenging. Our goal is to prepare students for admission to highly competitive colleges and for a wide range of careers in politics, law, journalism, business, science, mathematics, and the arts.

All students engage in a three-year chronological study of American History. Our goal is to make history come alive through the use of primary source documents, films, biographies, literature, and creative teaching techniques. Supported by the Gilder-Lehrman Institute, students gain firsthand knowledge of the key events in American History through trips to sites and cities of historic importance and through participation in special seminars with guest speakers. We also offer honors-level, Advanced Placement, and elective courses in mathematics, science, constitutional and criminal law, literature, foreign languages, history, and the arts.

A special component of our program focuses on the development of college-level research skills and methodologies; therefore, students are supported by school and college faculty in the process of pursuing individualized research projects. Through our collaboration with Lehman College, students have access to its campus library and athletic facilities and may take credit-bearing college classes and seminars in their junior and senior years. After school, students may participate in a wide variety of extracurricular activities and PSAL sports. In all of our endeavors, we seek to encourage in our students a love for learning and an inquisitive spirit.

For September 2011 admission, 16,436 students listed High School of American Studies at Lehman College as a choice on their application and 177 offers were made.

## ► Queens High School for the Sciences at York College

**94-50 159th Street, Jamaica, New York 11433**

**Telephone:** (718) 657-3181 • **Website:** [www.qhss.org](http://www.qhss.org)

Queens High School for the Sciences at York College is dedicated to providing a rigorous curriculum emphasizing the sciences and mathematics in collaboration with York College. The philosophy of the school is that students are more successful in life when nurtured in a small learning community. The mission of the school is to nurture and develop a community of diligent learners and independent thinkers, to inspire students to attain academic excellence, and to prepare them to contend with the competitive environment and the challenges of higher education.

In addition to the New York State standard high school curriculum, the school offers a wide range of elective courses in all subjects. A number of Advanced Placement courses, including English Language and Composition, English Literature, U.S. History, World History, Spanish Language, French Language, Music Theory, Calculus AB, Calculus BC, Biology, Chemistry, Physics B, and Environmental Science, are available to those who qualify. Students also have the opportunity to enroll in College Now courses, such as Political Science, Sociology, Computer Music, Computer Programming, Chinese, and Latin. Course offerings may vary from year to year.

Since the school is located on the campus of York College, students enjoy the state-of-the-art facilities such as the library, gymnasium, pool, theater, and cafeteria/food court throughout their high school career.

For September 2011 admission, 16,597 students listed Queens High School for the Sciences at York College as a choice on their application and 143 offers were made.

## ► Staten Island Technical High School

**485 Clawson Street, Staten Island, New York 10306**

**Telephone:** (718) 667-5725 • **Website:** [www.siths.org](http://www.siths.org)

**E-Mail:** [gpo@SITHS.org](mailto:gpo@SITHS.org)

Staten Island Technical High School offers a challenging curriculum that emphasizes high-level achievement in a variety of disciplines: mathematics, science, computers, engineering, humanities, and the performing arts.

Facilities include state-of-the-art science, engineering, performing arts, and computer laboratories. Along with a highly engaging and demanding core curriculum, all students are scheduled for technical courses in Computer Software Applications, Introduction to Robotics/Engineering Survey, Electronics, AutoCAD, Forensic Science, and Television Studio Production. Students may participate in the school's Science Engineering Research Program (SERP), FIRST Robotics STEM programs, as well as selected internships.

The students at Staten Island Tech have the opportunity to take Advanced Placement courses in Physics, Chemistry, Biology, Psychology, Calculus, English, Social Studies, and Russian. In addition, elective courses are offered in Advanced AutoCAD, Forensics Science, Law, Robotics, Research, Television Studio Production, and FIRST Robotics. Students interested in the performing arts may participate in band, ensembles, dance, drama, SING, and musicals.

As part of the school's co-curricular and extended day programs, students have the opportunity to participate in a variety of activities, such as student government, National Honor Society, publications, performing arts programs, PSAL teams that foster the development of a well-rounded scholar athlete, and various accredited college courses offered on site.

For September 2011 admission, 14,449 students listed Staten Island Tech as a choice on their application and 352 offers were made.



## ► Stuyvesant High School

**345 Chambers Street, New York, New York 10282-1099**

**Telephone:** (212) 312-4800 • **Website:** [www.stuy.edu](http://www.stuy.edu)

Stuyvesant High School, founded in 1904, has been and continues to be committed to excellence in education. The school's enriched curriculum includes required courses for graduation and affords its students the opportunity to take advanced courses in mathematics and science, calculus, qualitative analysis, organic chemistry, and astronomy. In addition, a wide range of electives in other disciplines is available. The Technology Department course offerings include technology computer drafting, computer science, and robotics. Students interested in music may participate in symphonic band, symphony orchestra, jazz band, and various choral groups and ensembles.

Students have the opportunity to participate in independent research and to take college courses at New York University, Hunter College, and The City College of New York. Stuyvesant High School prides itself on the number of National Merit, National Achievement, National Hispanic Scholars, and Intel Science Talent Research recipients and finalists it has garnered every year. Stuyvesant High School is also proud of its extensive extracurricular program. There are 31 athletic teams, 20 major publications, and an active and elaborate system of student government, making it one of the most unique high schools in America.

For September 2011 admission, 24,704 students listed Stuyvesant High School as a choice on their application and 937 offers were made.

## ► Fiorello H. LaGuardia High School of Music & Art and Performing Arts

**100 Amsterdam Avenue, New York, New York 10023**

**Telephone:** (212) 496-0700 • **Website:** [www.laguardiahs.org](http://www.laguardiahs.org)

**E-Mail:** [laguardiaadmissions@yahoo.com](mailto:laguardiaadmissions@yahoo.com)

The Fiorello H. LaGuardia High School of Music & Art and Performing Arts enjoys an international reputation as the first and foremost high school dedicated to nurturing students gifted in the arts. LaGuardia High School continues to be the model for schools for the arts throughout the world because the school provides a uniquely balanced educational experience that includes both demanding conservatory-style training and a challenging, comprehensive academic program. The conservatory programs include Dance, Drama, Instrumental and Vocal Music, Fine Arts, and Technical Theatre.

Students in the **Dance** program will study ballet and modern dance; supplementary courses include: dance history, choreography, theatre dance (tap and jazz), career management, and survival skills. In **Drama**, the focus is on theatre preparation through courses in acting, voice and diction, physical techniques, theatre history, and script analysis. **Instrumental Music** and **Vocal Music** courses include: sight singing, diction, music theory, and music history. The Vocal Music Studio also includes performing opportunities in musical theatre, opera, choir, chamber music, and solo voice, and training in Italian, German, and French vocal literature. The Instrumental Music Studio courses include four symphonic orchestras, three concert bands, and two jazz bands, as well as electives in chamber music, conducting, and electronic music. In the **Fine Arts** program, drawing, watercolor, 3-D design, oil/acrylic painting, ceramics, photography, sculpture, illustration, advanced painting, and drawing are offered. In **Technical Theatre**, the focus is on practical theatre training in scenic carpentry, costume construction, drafting, electronics, sound properties, stage management, and design. Each year's program culminates in performances and exhibitions.

Each studio requires a substantial time commitment after school, including rehearsals and performances, as well as the practical application of technical theatre and gallery management techniques. Longer school days are expected during performance times, and students are required to be present and participatory during these extra hours.

**Auditions** will be held at the school. See pages 10-11 for audition information regarding LaGuardia High School.

For September 2011 admission, 962 students received one or more offers to the programs at LaGuardia High School from a pool of almost 11,000 applicants.





- September 14, 2011 – October 12, 2011 ► Meet with your school guidance counselor
- October 12, 2011 ► Last day to register for the Specialized High Schools Admissions Test (SHSAT)
- October 21, 2011 ► Admission Ticket available for distribution
- December 2, 2011 ► Deadline for submission of the High School Admissions Application

## SPECIALIZED HIGH SCHOOLS ADMISSIONS TEST (SHSAT) DATES AND LOCATIONS

All current 8th and 9th grade students in public, private, and parochial schools applying to one or more of the Specialized High Schools in New York City must take the SHSAT. Testing sites are specified below, and students are assigned to a testing site based on the geographic district in which the student's school is located. Students applying only to Fiorello H. LaGuardia High School of Music & Art and Performing Arts do **not** have to take the SHSAT; entrance is based on audition results and a review of their academic record.

TEST DATES (For location, see chart below) (Students MUST test on the date specified on their Admission Ticket.)	
► All current 8th grade students	Saturday, October 29, 2011 Sunday, October 30, 2011
► All current 9th grade students ► 8th and 9th grade students with special needs and approved 504 Accommodations	Saturday, November 5, 2011
► 9th grade Sabbath observers ► Sabbath observers with special needs and approved 504 Accommodations ► Make-up test with permission only	Sunday, November 20, 2011 Test location is Brooklyn Technical High School only
► Students new to NYC (Records must show that you arrived in NYC after the November make-up test)	End of summer 2012

## TESTING LOCATIONS

8th and 9th Grade Students attending schools in:	TESTING SITE	ADDRESS
Manhattan	Stuyvesant High School	<b>345 Chambers Street, New York, NY 10282-1099</b> Tel: (212) 312-4800 <b>Subways:</b> 1, 2, 3, 9, A, C, E to Chambers Street; 4, 5, J, Z to Fulton Street-Broadway-Nassau; 6 to Brooklyn Bridge; N, Q to Canal Street; R to City Hall <b>Buses:</b> BM1, BM2, BM3, BM4, BXM18, M05, M20, M22, QM11, QM25, QM7, QM8, X1, X10, X11, X12, X15, X17, X19, X27, X28, X3, X4, X7, X8, X9
Bronx	The Bronx High School of Science	<b>75 West 205<sup>th</sup> Street, Bronx, NY 10468</b> Tel: (718) 817-7700 <b>Subways:</b> 1 to 238th Street; 4, B, D to Bedford Park Boulevard <b>Buses:</b> BX1, BX2, BX22, BX39 to West 205 <sup>th</sup> Street & Paul Avenue; X32 to West 205 <sup>th</sup> Street
Brooklyn Districts 13, 14, 15, 16, 17, 18, 20, 21, 22, 23, 32	Brooklyn Technical High School	<b>29 Fort Greene Place, Brooklyn, NY 11217</b> Tel: (718) 804-6400 <b>Subways:</b> 2, 3, 4, 5 to Nevins Street; A to Hoyt & Schermerhorn; B, Q, R to DeKalb Avenue; C to Lafayette Avenue; D, N to Atlantic Avenue; F to Jay Street-Borough Hall; G to Fulton Street; M to Lawrence Street <b>Buses:</b> B103, B25, B26, B38, B41, B45, B52, B54, B57, B62, B63, B65, B67, B69
Brooklyn District 19 Queens Districts 27, 29	John Adams High School	<b>101-01 Rockaway Boulevard, Ozone Park, NY 11417</b> Tel: (718) 322-0500 <b>Subway:</b> A to 104 <sup>th</sup> Street <b>Buses:</b> Q11, Q21, Q37, Q41, Q53, Q7, Q8, QM15
Queens Districts 24, 25, 26, 28, 30	Long Island City High School	<b>14-30 Broadway, Long Island City, NY 11106-3402</b> Tel: (718) 545-7095 <b>Subways:</b> F to 21st Street; M, R to Steinway Street; N, Q to Broadway <b>Buses:</b> Q18
Staten Island	Staten Island Technical High School	<b>485 Clawson Street, Staten Island, NY 10306</b> Tel: (718) 667-5725 <b>Subways:</b> Staten Island Railway (SIR) to New Dorp <b>Buses:</b> S57, S74, S76, S78, S79, X1, X15, X2, X3, X4, X5, X7, X8, X9

## ▶▶▶ ADMISSIONS PROCESS

### Fiorello H. LaGuardia High School of Music & Art and Performing Arts

▶ Admission is based on a competitive audition and review of a student's record to ensure success in both the demanding studio work and the challenging academic programs.

▶ Successful candidates will exhibit an intermediate to advanced level of proficiency in all art forms. Students are evaluated based on preparation for the audition and level of commitment to their art form, technical proficiency, and artistic expression. Most students receiving an offer for

one or more of the studios at LaGuardia High School will score a 3-5 out of a possible 5 points on the studio rubric.

▶ All applicants must submit a copy of their previous academic year's report card and/or transcript at the time of the audition. Students are evaluated solely on the official marks awarded during the previous academic school year. No reevaluation will be done based on any subsequent improved academic performance.

## ▶▶▶ AUDITION INFORMATION

Only students who are residents of New York City are eligible to apply and audition.

Students may audition for the following studios:

**DANCE ■ DRAMA ■ FINE ART ■ INSTRUMENTAL MUSIC ■ TECHNICAL THEATRE ■ VOCAL MUSIC**

Students should bring a copy of their June 2011 report card for each audition. Students may also wish to bring a light snack. Individual auditions may be delayed and students may be kept for a full day. It is the responsibility of candidates to be aware of all audition procedures as described in this handbook and in the *Directory of the New York City Public High Schools*.

**Dance students** will participate in two classes, one ballet and one modern, in which an evaluation is made as to the student's potential to succeed in the specific training offered. All candidates are expected to bring dance clothes for the audition, including footless tights and a leotard.

**Drama students** should be prepared to perform two contrasting one-minute monologues. The applicant will be asked to do an impromptu reading and participate in an interview. Attire should allow free movement since applicants may be asked to demonstrate how well they move physically.

**Fine Art students** will need a portfolio of 10-20 pieces of *original* artwork done in a variety of media. The artwork should be from observation, imagination, and memory, and labeled appropriately. Photographs—not originals—of three-dimensional works may be included. For their audition, students will be given three drawing assignments, including drawing the human figure from observation, drawing a still life from memory, and creating a drawing in color, based on imagination. All drawing materials for the audition will be supplied by the school at the time of the audition.

**Instrumental Music students** should come to their audition with their instruments, except for those students who will audition on piano, percussion, tuba, double bass, and harp. These instruments will be provided by the school at the audition. In addition, amplifiers will be provided by the school at the audition for electric guitarists. Students are expected to perform prepared selections without accompaniment. Applicants will be tested for rhythm and tonal memory and will be asked to complete a sight-reading of a given selection.

**Technical Theatre students** should prepare a typed 350-word essay that describes their experience in any aspect of technical theatre, for example, lights, scenery design, sound design, or special effects. Applicants will be asked to participate in a small-group, hands-on practical in one or more aspects of technical theatre, as well as in an interview.

**Vocal Music students** should prepare a song to sing without accompaniment for their audition from a song list provided at [www.laguardiahs.org](http://www.laguardiahs.org). The musical selection can be classical or popular in style. Students will be asked to sing back melodic patterns and tap back rhythmic patterns.

## 2011–2012 AUDITION DATES

All auditions are held at LaGuardia High School. Dates are scheduled according to the borough in which your school is located, not where you live, and by the first letter of the student's last name.

AUDITION GROUP	DATE	START TIME
<b>Brooklyn A – L</b> (Students auditioning for a single studio other than Technical Theatre)	Saturday, November 05, 2011	8:00 AM
<b>Brooklyn M – Z</b> (Students auditioning for a single studio other than Technical Theatre)	Saturday, November 05, 2011	12:00 Noon
<b>Brooklyn A – Z</b> (Students auditioning for two or more studios or Technical Theatre)	Sunday, November 06, 2011	8:00 AM
<b>Manhattan A – F</b> (Students auditioning for a single studio other than Technical Theatre) <b>Queens/Staten Island A – L</b> (Students auditioning for a single studio in Dance or Drama only)	Saturday, November 19, 2011	8:00 AM
<b>Manhattan G – L</b> (Students auditioning for a single studio other than Technical Theatre)	Saturday, November 19, 2011	12:00 Noon
<b>Manhattan A – Z</b> (Students auditioning for two or more studios or Technical Theatre)	Sunday, November 20, 2011	8:00 AM
<b>Bronx A – L</b> (Students auditioning for a single studio other than Technical Theatre)	Saturday, December 03, 2011	8:00 AM
<b>Bronx M – Z</b> (Students auditioning for a single studio other than Technical Theatre)	Saturday, December 03, 2011	12:00 Noon
<b>Bronx A – Z</b> (Students auditioning for two or more studios or Technical Theatre)	Saturday, December 03, 2011	8:00 AM
<b>Manhattan M – R</b> (Students auditioning for a single studio other than Technical Theatre) <b>Queens/Staten Island M – Z</b> (Students auditioning for a single studio in Dance or Drama only)	Sunday, December 04, 2011	8:00 AM
<b>Manhattan S – Z</b> (Students auditioning for a single studio other than Technical Theatre)	Sunday, December 04, 2011	12:00 Noon
<b>Queens/Staten Island A – Z</b> (Students auditioning for two or more studios or Technical Theatre)	Saturday, December 17, 2011	8:00 AM
<b>Queens/Staten Island A – L</b> (Students auditioning for a single studio in Instrumental or Vocal Music or Fine Art only. For Dance or Drama auditions, see November 19.)	Sunday, December 18, 2011	8:00 AM
<b>Queens/Staten Island M – Z</b> (Students auditioning for a single studio in Instrumental or Vocal Music or Fine Art only. For Dance or Drama auditions, see December 4.)	Sunday, December 18, 2011	12:00 Noon

**You must arrive on time with your Admission Ticket and prepared as outlined in the audition guidelines listed on page 10. All audition ending times vary according to studio. There is no guarantee that you will be able to audition for more than 2 studios on a given day.**

### ▶▶▶ AUDITION EXCEPTIONS

If your audition date conflicts with a religious observance, you may audition on either the Saturday or Sunday of your school's scheduled weekend.

**Students taking the SHSAT** who have a conflict with the audition schedule are to report for their audition(s) on the weekend assigned to their borough on the Saturday or Sunday for which there is not a conflict with the SHSAT.

### ▶▶▶ AUDITIONS FOR STUDENTS NEW TO NYC

End of summer 2012 (official records must indicate that you arrived in NYC after the last audition date).



### ▶▶▶ STEPS IN THE APPLICATION PROCESS

#### 1 Step One: Contact Your Guidance

**Counselor.** You should contact your school guidance counselor to indicate your intention to take the SHSAT and/or audition for LaGuardia High School.

#### 2 Step Two: Obtain a Test or Audition Ticket.

Prior to the testing/audition date, your school guidance counselor will provide you with a **SHSAT Admission Ticket and/or a ticket for admission to the LaGuardia High School auditions.** This ticket will indicate the location of the test/audition site, the date and time of the SHSAT/audition, your student ID number, and the school code number of your current school. If you have a conflict with the test date to which you have been assigned, **inform your counselor immediately** to arrange an alternate test date. **Once Admission Tickets have been issued, students are expected to test on the date and time indicated on their ticket.** Your test site is based on the location of your current school, not where you live. Students with special needs or approved 504 accommodations should check their Admission Ticket and make sure they are scheduled for the appropriate date (see page 9) with the appropriate accommodations. Inform your counselor immediately if there are any concerns.

#### 3 Step Three: Rank Your Choices (SHSAT only).

On the back of the Admission Ticket you will need to rank, in priority order, your choices for the Specialized High Schools to which you want to apply. You will need to submit your ranking of the Specialized High School(s) on the day of the test, and the ticket must be signed by your parent/guardian. You and your parent/guardian will need to determine the Specialized High School(s) for which you wish to be considered and the ranking order in which you will list them on your answer sheet. Students will be considered for admission to a Specialized High School based on choices made on the answer sheet and the score attained on the SHSAT. Please note the choices of schools made on the SHSAT answer sheet will only include the Specialized High Schools. Choices of other high school programs should be made on the High School Admissions Application. Consider the focus of the academic program, the size of the school, travel arrangements, as well as travel time. You may choose to apply to only one school, or you can choose to apply to as many as eight schools. To increase your chances of being offered a seat in one of the Specialized High Schools, you are encouraged to choose as many schools as possible that interest you; however, you should only list schools that you wish to attend if you are offered a seat. **Once choices have been submitted on the day of the test, they may not be changed.**

#### 4 Step Four: Complete and Submit Your High School Admissions Application.

In order for you to receive the result of your SHSAT or the result of your audition(s) at LaGuardia High School and to be considered for admission to a Specialized High School, **you must complete and submit to your guidance counselor a New York City Public High School Admissions Application prior to the deadline of December 2, 2011.** Please remember to fill in the appropriate bubbles on the application to indicate that you will take or have taken the SHSAT and/or are applying to one or more programs at LaGuardia High School. Additional information about the High School Admissions Process is online at [www.nyc.gov/schools/ChoicesEnrollment/High](http://www.nyc.gov/schools/ChoicesEnrollment/High).

### ▶▶▶ SHSAT TESTING PROCEDURES

▶ Remember to bring your **Admission Ticket with you** to your assigned test site on the day of the test. It is important to arrive at the test site at the time indicated on your SHSAT **Admission Ticket** even though the test may not begin immediately after arrival. Students arriving without an Admission Ticket are not guaranteed admittance. Please be advised that your picture will be taken at the test site prior to the start of the test.

▶ Before you begin the test, you will be asked to read and sign a statement indicating that you are a resident of New York City, are well enough to take the test, and are taking it at the appropriate grade level. Students who sign this statement but do not meet the requirements specified will be disqualified from acceptance to any of the Specialized High Schools. **If you do not feel well, advise the test proctor immediately; do not begin the test, and do not sign the statement.** Once you have begun the test, you may not—either then or at a later date—request a make-up test because of illness.

**SHSAT STUDENTS PLEASE NOTE:** If you believe there is interference or testing irregularity during any part of this test, you must bring the matter to the attention of the proctor immediately. This may include a misprinted test booklet, undue noise, or improper student behavior. The proctor will attempt to remedy the situation and take a written statement from you at the end of the test.

If you suspect any proctoring or testing irregularities during the test administration, you must submit a letter about the situation to the Office of Student Enrollment, 52 Chambers Street, Room 415, New York, NY, 10007. This letter must be sent by certified mail with proof of delivery and **postmarked no later than one week** after the test administration. Letters postmarked after this will not be considered.

## ▶▶▶ AUDITIONING FOR LAGUARDIA HIGH SCHOOL

- ▶ If you are interested in applying to one or more of the six programs at LaGuardia High School, review the audition requirements listed on page 10 of this handbook and also in the *Directory of the New York City Public High Schools* and prepare for your auditions.
- ▶ To audition for one or more of the programs at LaGuardia High School, inform your guidance counselor of your intention to audition and indicate for which studio(s) you wish to audition. Your guidance counselor will provide you with an Audition Ticket prior to the audition date.
- ▶ You must also complete the New York City Public High School Admissions Application. On your High School Admissions Application you will be required to indicate the LaGuardia High School studio(s) for which you wish to be considered based on your audition.

## ▶▶▶ NOTIFICATION INFORMATION

- ▶ In February 2012, you will be notified as to whether or not you received an offer(s) to the Specialized High Schools. If you qualify for an offer to one of the Specialized High Schools based on your test score and/or audition, then your score and your ranking of schools will be used to determine your offer.
- ▶ If you audition for one or more of the programs at LaGuardia High School and take the SHSAT, it is possible for you to receive an offer to one of the Specialized High Schools and one or more of the programs at LaGuardia High School.
- ▶ If you receive an offer to a Specialized High School you may, at the same time, receive a match to one of the other high school choices that you submitted on your New York City High School Admissions Application. At this time you may accept either your Specialized High School offer or your other high school offer.

## ▶▶▶ ADMISSIONS PROCESS

### Specialized High Schools Admissions Test (SHSAT)

**The process is designed to match students based on their SHSAT scores and how they ranked the Specialized High Schools.\***

- ▶ Acceptance to a Specialized High School is based first on the student's test score, then on the priority order in which the student placed the Specialized High Schools and on seat availability.
- ▶ All scores of the students taking the test are ranked from highest score to lowest score.
- ▶ The student with the highest score is placed in his/her first choice (highest prioritized school).
- ▶ Starting from the highest score on down, each student, in turn, is placed in his/her highest prioritized school in which seats are still available. Therefore, if all the seats in the student's first-choice school have been offered to students who scored higher,

he/she is placed in his/her second-choice school if seats are available. If all the seats in his/her second-choice school have been given to students who scored higher, the student is offered a seat in his/her third-choice school if there are still seats available, and so on. This process continues until there are no seats available in any of the eight Specialized High Schools.

From year to year, the number of offers and projected seats for each Specialized High School may be subject to an increase or decrease based on school enrollment.

*\*This process was implemented beginning with the entering class of September 2003.*

## ▶▶▶ ADDITIONAL SHSAT INFORMATION

### Alternate Test Dates

- ▶ If your test date conflicts with a religious observance, please notify your school counselor immediately after receiving your test date, and an alternate test date will be arranged.
- ▶ If you are ill and unable to take the test on your scheduled date, when you return to school immediately notify your counselor, present medical documentation, and request to take the SHSAT on the Make-Up Test Day. Only valid make-up requests submitted to counselors with the required documentation by Wednesday, November 9, 2011 will be considered. **Students will NOT be admitted to the make-up test without a valid Admission Ticket for the Make-Up Test Day.**
- ▶ Before you begin the test, you will be asked to read and sign a statement indicating that you are well enough to take the test and are taking it at the appropriate grade level. **If you do not feel well, advise the test proctor immediately; do not begin the test, and do not sign the statement.** Once you have begun the test, you may not—either then or at a later date—request a make-up test because of illness. **Any requests for a make-up test made after you have begun the test will not be honored.**

### Special Needs Students

Students classified by the Committee on Special Education as having a disability or students with approved 504 Plans may be eligible for test accommodation(s) if prescribed in their Individualized Education Programs (IEPs) or approved 504 Plans. The student's current school, including private and parochial schools, is responsible for submitting the IEP and/or approved 504 Plan documentation in the fall during the SHSAT registration process. Please note that the use of a calculator or mathematics tables is not allowed for the Mathematics section because the test measures students' proficiencies involving calculations. Similarly, because the Verbal section of the test measures reading comprehension, passages may not be read aloud in the Verbal section.

Students with special needs or approved 504 Accommodations should check their Admission Ticket immediately and make sure they are scheduled to test on the appropriate date (see page 9) with the appropriate accommodations. Inform your counselor immediately if there are any concerns.



## The Specialized High Schools Admissions Test has two sections, Verbal and Mathematics.

### VERBAL SECTION (45 questions)

Verbal reasoning is measured by 5 questions on ordering sentences to form a paragraph and 10 questions on logical reasoning. Reading comprehension is measured by 5 reading selections, each of which is followed by 6 questions tapping your ability to understand, analyze, and interpret what you have read. You should not spend more than 75 minutes on this section. You may go back to this section after completing the Mathematics section.

### MATHEMATICS SECTION (50 questions)

This section consists of word problems and computation questions. It is recommended that you allow yourself 75 minutes on this section. If you finish early, you may go back to questions in either section.

## TEST MATERIALS

### You must bring to the testing session:

- ▶ an Admission Ticket signed by your parent/guardian with your Specialized High School choices
- ▶ sharpened Number 2 pencils (a ballpoint pen or other ink cannot be used for machine scoring)
- ▶ an eraser
- ▶ a non-calculator watch to keep track of your working time

**Do not bring a calculator or any other computation aids. Do not bring electronic devices of any type, including cell phones, beepers, pagers, mp3 players, cameras, or devices that have image-capturing capabilities, to the test site. Such devices will not be permitted.**

### For each student, the testing site will provide:

- ▶ a test booklet
- ▶ a separate answer sheet
- ▶ scrap paper for use in solving logical reasoning and mathematics problems, which will be collected at the end of the test

## FILLING IN THE ANSWER SHEET

Before taking the test, you will need to provide information such as your name, student ID number, school number, and school choices on your answer sheet.

It is important to fill in the bubbles completely, so that your score will not be delayed.

In **Grid 5** bubble in your name as it appears in your school records and on your high school application. Do not use your nickname or your “American” name. For example, if your name on school records is Robert, bubble in that name, even if most people call you “Robbie.” Or if your name on school records is Mei-Ling, bubble in that name, even if most people call you “Melanie.” See examples below.

**GRID 5 EXAMPLE 1**

<b>5. FIRST NAME (please print)</b>											
R	O	B	E	R	T						
○	○	○	○	○	○	○	○	○	○	○	○
-	-	-	-	-	-	-	-	-	-	-	-

<b>5. FIRST NAME (please print)</b>											
R	O	B	B	I	E						
○	○	○	○	○	○	○	○	○	○	○	○
-	-	-	-	-	-	-	-	-	-	-	-

**GRID 5 EXAMPLE 2**

<b>5. FIRST NAME (please print)</b>											
M	E	I	-	L	I	N	G				
○	○	○	○	○	○	○	○	○	○	○	○
-	-	-	-	-	-	-	-	-	-	-	-

<b>5. FIRST NAME (please print)</b>											
M	E	L	A	N	I	E					
○	○	○	○	○	○	○	○	○	○	○	○
-	-	-	-	-	-	-	-	-	-	-	-

**Grid 6** is for your choice of Specialized High Schools only. **If Grid 6 is not marked correctly, your admission to a Specialized High School will be affected because your admission is based on the score you attain and the order in which you rank your school preferences.** Therefore, it is very important that you make your decisions about ranking schools before the day of the test. Discuss the schools in which you are interested with your parents/guardians and then together determine the order in which you will list them on the answer sheet. Enter these rankings on your Admission Ticket so that you will be able to carefully copy them onto Grid 6 on your answer sheet at the test site.

**Fill in ONE and only ONE circle for each school for which you wish to be considered.** You may make as few as one or as many as eight choices. To increase your chances of receiving an offer to one of the Specialized High Schools, you are encouraged to make more than one choice. **You must fill in a first choice school.** Fill in only one school for each choice. Fill in only one circle in a row and only one circle in a column. Do not fill in a school more than once. Do not fill in the same school for each choice.

**EXAMPLES OF CORRECT GRID 6**

6. CHOICES OF SPECIALIZED HIGH SCHOOLS		CHOICES							
SCHOOLS		1st choice	2nd choice	3rd choice	4th choice	5th choice	6th choice	7th choice	8th choice
Bronx Science		<input type="radio"/>	<input type="radio"/>	<input checked="" type="radio"/>	<input type="radio"/>	<input type="radio"/>	<input type="radio"/>	<input type="radio"/>	<input type="radio"/>
Brooklyn Latin		<input type="radio"/>	<input type="radio"/>	<input type="radio"/>	<input type="radio"/>	<input type="radio"/>	<input type="radio"/>	<input type="radio"/>	<input checked="" type="radio"/>
Brooklyn Tech		<input checked="" type="radio"/>	<input type="radio"/>	<input type="radio"/>	<input type="radio"/>	<input type="radio"/>	<input type="radio"/>	<input type="radio"/>	<input type="radio"/>
HS Math, Sci., & Engineering		<input type="radio"/>	<input type="radio"/>	<input type="radio"/>	<input checked="" type="radio"/>	<input type="radio"/>	<input type="radio"/>	<input type="radio"/>	<input type="radio"/>
HS American Studies/Lehman		<input type="radio"/>	<input type="radio"/>	<input type="radio"/>	<input type="radio"/>	<input type="radio"/>	<input checked="" type="radio"/>	<input type="radio"/>	<input type="radio"/>
Queens Sci./York College		<input type="radio"/>	<input type="radio"/>	<input type="radio"/>	<input type="radio"/>	<input checked="" type="radio"/>	<input type="radio"/>	<input type="radio"/>	<input type="radio"/>
Staten Island Tech		<input checked="" type="radio"/>	<input type="radio"/>	<input type="radio"/>	<input type="radio"/>	<input type="radio"/>	<input type="radio"/>	<input type="radio"/>	<input type="radio"/>
Stuyvesant		<input type="radio"/>	<input checked="" type="radio"/>	<input type="radio"/>	<input type="radio"/>	<input type="radio"/>	<input type="radio"/>	<input type="radio"/>	<input type="radio"/>

6. CHOICES OF SPECIALIZED HIGH SCHOOLS		CHOICES							
SCHOOLS		1st choice	2nd choice	3rd choice	4th choice	5th choice	6th choice	7th choice	8th choice
Bronx Science		<input type="radio"/>	<input type="radio"/>	<input type="radio"/>	<input type="radio"/>	<input type="radio"/>	<input type="radio"/>	<input type="radio"/>	<input type="radio"/>
Brooklyn Latin		<input type="radio"/>	<input type="radio"/>	<input type="radio"/>	<input type="radio"/>	<input type="radio"/>	<input type="radio"/>	<input type="radio"/>	<input type="radio"/>
Brooklyn Tech		<input type="radio"/>	<input type="radio"/>	<input type="radio"/>	<input type="radio"/>	<input type="radio"/>	<input type="radio"/>	<input type="radio"/>	<input type="radio"/>
HS Math, Sci., & Engineering		<input type="radio"/>	<input type="radio"/>	<input type="radio"/>	<input type="radio"/>	<input type="radio"/>	<input type="radio"/>	<input type="radio"/>	<input type="radio"/>
HS American Studies/Lehman		<input type="radio"/>	<input type="radio"/>	<input type="radio"/>	<input type="radio"/>	<input type="radio"/>	<input type="radio"/>	<input type="radio"/>	<input type="radio"/>
Queens Sci./York College		<input checked="" type="radio"/>	<input type="radio"/>	<input type="radio"/>	<input type="radio"/>	<input type="radio"/>	<input type="radio"/>	<input type="radio"/>	<input type="radio"/>
Staten Island Tech		<input type="radio"/>	<input type="radio"/>	<input type="radio"/>	<input type="radio"/>	<input type="radio"/>	<input type="radio"/>	<input type="radio"/>	<input type="radio"/>
Stuyvesant		<input checked="" type="radio"/>	<input type="radio"/>	<input type="radio"/>	<input type="radio"/>	<input type="radio"/>	<input type="radio"/>	<input type="radio"/>	<input type="radio"/>

**You MUST fill in a first choice school.**

**EXAMPLES OF INCORRECT GRID 6**

~~6. CHOICES OF SPECIALIZED HIGH SCHOOLS~~  
~~Indicate your school choice in order of preference.~~  
~~• Fill in only one school for each choice.~~  
~~• You must fill in a first choice school.~~  
~~• Fill in only one circle in a row and only one circle in a column.~~

SCHOOLS		1st choice	2nd choice	3rd choice	4th choice	5th choice	6th choice	7th choice	8th choice
Bronx Science		<input type="radio"/>	<input type="radio"/>	<input type="radio"/>	<input type="radio"/>	<input type="radio"/>	<input type="radio"/>	<input type="radio"/>	<input type="radio"/>
Brooklyn Latin		<input checked="" type="radio"/>	<input type="radio"/>	<input type="radio"/>	<input type="radio"/>	<input type="radio"/>	<input type="radio"/>	<input type="radio"/>	<input type="radio"/>
Brooklyn Tech		<input type="radio"/>	<input type="radio"/>	<input type="radio"/>	<input type="radio"/>	<input type="radio"/>	<input type="radio"/>	<input type="radio"/>	<input type="radio"/>
HS Math, Sci., & Engineering		<input checked="" type="radio"/>	<input type="radio"/>	<input type="radio"/>	<input type="radio"/>	<input type="radio"/>	<input type="radio"/>	<input type="radio"/>	<input type="radio"/>
HS American Studies/Lehman		<input type="radio"/>	<input type="radio"/>	<input type="radio"/>	<input type="radio"/>	<input type="radio"/>	<input type="radio"/>	<input type="radio"/>	<input type="radio"/>
Queens Sci./York College		<input type="radio"/>	<input checked="" type="radio"/>	<input type="radio"/>	<input type="radio"/>	<input type="radio"/>	<input type="radio"/>	<input type="radio"/>	<input type="radio"/>
Staten Island Tech		<input type="radio"/>	<input type="radio"/>	<input type="radio"/>	<input checked="" type="radio"/>	<input type="radio"/>	<input type="radio"/>	<input type="radio"/>	<input type="radio"/>
Stuyvesant		<input type="radio"/>	<input type="radio"/>	<input type="radio"/>	<input type="radio"/>	<input type="radio"/>	<input type="radio"/>	<input type="radio"/>	<input type="radio"/>

**DO NOT fill in more than one circle in a column.**

~~6. CHOICES OF SPECIALIZED HIGH SCHOOLS~~  
~~Indicate your school choice in order of preference.~~  
~~Fill in only one school for each choice.~~  
~~• You must fill in a first choice school.~~  
~~• Fill in only one circle in a row and only one circle in a column.~~

SCHOOLS		1st choice	2nd choice	3rd choice	4th choice	5th choice	6th choice	7th choice	8th choice
Bronx Science		<input checked="" type="radio"/>	<input type="radio"/>	<input type="radio"/>	<input type="radio"/>	<input type="radio"/>	<input type="radio"/>	<input type="radio"/>	<input type="radio"/>
Brooklyn Latin		<input type="radio"/>	<input type="radio"/>	<input checked="" type="radio"/>	<input type="radio"/>	<input type="radio"/>	<input type="radio"/>	<input type="radio"/>	<input type="radio"/>
Brooklyn Tech		<input checked="" type="radio"/>	<input type="radio"/>	<input type="radio"/>	<input checked="" type="radio"/>	<input type="radio"/>	<input type="radio"/>	<input type="radio"/>	<input type="radio"/>
HS Math, Sci., & Engineering		<input type="radio"/>	<input type="radio"/>	<input type="radio"/>	<input type="radio"/>	<input type="radio"/>	<input type="radio"/>	<input type="radio"/>	<input type="radio"/>
HS American Studies/Lehman		<input type="radio"/>	<input type="radio"/>	<input type="radio"/>	<input type="radio"/>	<input type="radio"/>	<input type="radio"/>	<input type="radio"/>	<input type="radio"/>
Queens Sci./York College		<input type="radio"/>	<input type="radio"/>	<input type="radio"/>	<input type="radio"/>	<input type="radio"/>	<input type="radio"/>	<input type="radio"/>	<input type="radio"/>
Staten Island Tech		<input type="radio"/>	<input type="radio"/>	<input type="radio"/>	<input type="radio"/>	<input type="radio"/>	<input type="radio"/>	<input type="radio"/>	<input type="radio"/>
Stuyvesant		<input type="radio"/>	<input type="radio"/>	<input type="radio"/>	<input type="radio"/>	<input type="radio"/>	<input type="radio"/>	<input type="radio"/>	<input type="radio"/>

**DO NOT fill in more than one circle in a row.**

~~6. CHOICES OF SPECIALIZED HIGH SCHOOLS~~  
~~Indicate your school choice in order of preference.~~  
~~Fill in only one school for each choice.~~  
~~• You must fill in a first choice school.~~  
~~• Fill in only one circle in a row and only one circle in a column.~~

SCHOOLS		1st choice	2nd choice	3rd choice	4th choice	5th choice	6th choice	7th choice	8th choice
Bronx Science		<input type="radio"/>	<input type="radio"/>	<input type="radio"/>	<input type="radio"/>	<input type="radio"/>	<input type="radio"/>	<input type="radio"/>	<input type="radio"/>
Brooklyn Latin		<input type="radio"/>	<input type="radio"/>	<input type="radio"/>	<input type="radio"/>	<input type="radio"/>	<input type="radio"/>	<input type="radio"/>	<input type="radio"/>
Brooklyn Tech		<input type="radio"/>	<input type="radio"/>	<input type="radio"/>	<input type="radio"/>	<input type="radio"/>	<input type="radio"/>	<input type="radio"/>	<input type="radio"/>
HS Math, Sci., & Engineering		<input type="radio"/>	<input type="radio"/>	<input type="radio"/>	<input type="radio"/>	<input type="radio"/>	<input type="radio"/>	<input type="radio"/>	<input type="radio"/>
HS American Studies/Lehman		<input type="radio"/>	<input type="radio"/>	<input type="radio"/>	<input type="radio"/>	<input type="radio"/>	<input type="radio"/>	<input type="radio"/>	<input type="radio"/>
Queens Sci./York College		<input type="radio"/>	<input type="radio"/>	<input type="radio"/>	<input type="radio"/>	<input type="radio"/>	<input type="radio"/>	<input type="radio"/>	<input type="radio"/>
Staten Island Tech		<input type="radio"/>	<input type="radio"/>	<input type="radio"/>	<input type="radio"/>	<input type="radio"/>	<input type="radio"/>	<input type="radio"/>	<input type="radio"/>
Stuyvesant		<input checked="" type="radio"/>	<input checked="" type="radio"/>	<input checked="" type="radio"/>	<input checked="" type="radio"/>	<input checked="" type="radio"/>	<input checked="" type="radio"/>	<input checked="" type="radio"/>	<input checked="" type="radio"/>

**DO NOT fill in the same school for each choice.**



**GRID 9**

**9. SCHOOL WHERE YOU ARE NOW ENROLLED**

Abraham Lincoln IS 171

NAME OF SCHOOL

School Code

1	9	K	1	7	1
0	0	●	0	0	0
●	1	(M)	●	1	●
2	2	(Q)	2	2	2
3	3	(X)	3	3	3
4	4	(R)	4	4	4
5	5	(W)	5	5	5
6	6		6	6	6
7	7		7	●	7
8	8		8	8	8
9	●		9	9	9

(P) Fill in for private or parochial schools only

**BOROUGH OF SCHOOL**

- Brooklyn (K)
- Manhattan (M)
- Queens (Q)
- Bronx (X)
- Staten Island (R)
- Out of NYC (W)

**TYPE OF SCHOOL**

- NYC Public
- Private or Parochial

In **Grid 9**, print the name of the school where you are now enrolled. Then print your school code exactly as it appears on your Admission Ticket or in the Feeder School List available from your test proctor. Bubble in the corresponding number or letter for each digit of your school code.

Next, bubble in the letter “P” if you attend a private or parochial school. Under “BOROUGH OF SCHOOL,” fill in the circle next to the name of the borough in which your school is located. Under “TYPE OF SCHOOL,” fill in the appropriate circle to indicate if it is a public or private/parochial school.

For example, a student who attends Abraham Lincoln IS 171 in Brooklyn should complete Grid 9 as shown in the example above. Fill in Grid 9 carefully: a bubbling error in Grid 9 may delay the reporting of your score.

**Answers must be recorded on the answer sheet to be counted. Answers left in the test booklet or on scrap paper will not be counted.**

When you are told to begin the test, mark your answers on the answer sheet by completely filling in the appropriate bubble (see example to the right). Make sure your marks are heavy and dark. Be careful not to make any stray marks on the answer sheet. If you change an answer, completely erase your first answer. Do not fold or tear the answer sheet.

**SAMPLE ANSWER MARKS**

1	(A)	(B)	(C)	(D)	●	RIGHT
2	(V)	(G)	(H)	(J)	(K)	WRONG
3	(A)	(B)	(C)	(D)	(E)	WRONG
4	(F)	(G)	(H)	(J)	(K)	WRONG
5	(A)	(B)	●	●	(E)	WRONG

There is only one correct answer to each question. If your answer sheet shows more than one mark in response to a question, that question will be scored as incorrect.

You may write in your test booklet or on the scrap paper provided to solve verbal or mathematics problems, but **your answers must be recorded on the answer sheet in order to be counted.** Information in the test booklet or on scrap paper will not be counted.

**▶▶▶ SHSAT SCORING, REPORTING, & REVIEW PROCEDURES**

Your SHSAT score is based on the number of correct answers marked. **There is no penalty for wrong answers.** If you are not sure of an answer, mark your best guess. Do not spend too much time on any one question. Answer each question as best you can or skip it and keep going. If you have time at the end of the test, you may go back.

Each answer sheet is scanned and scored electronically, and the number of correct answers, called a raw score, is determined for each test taker. Because there are several forms of the SHSAT, raw scores from different test forms cannot be compared directly. The test forms were developed to be as similar as possible, but they are not identical.

To make valid score comparisons, a raw score must be converted into another type of score that takes into account the differences between test forms. In a process called calibration, verbal and mathematics raw scores are converted into scaled scores. The raw scores and scaled scores are not proportional. In the middle of the range of scores, an increase of one raw score point may correspond to an increase of three or four scaled score points. At the top or bottom of the range of scores, an increase of one raw score point may correspond to 10-20 scaled score points. The reason for this difference is that the scaled scores have been adjusted to fit the normal

**GRID 10**

**10. STUDENT ID NUMBER**

3	2	1	-	4	5	6	-	7	7	8
0	0	0		0	0	0		0	0	0
1	1	●		1	1	1		1	1	1
2	●	2		2	2	2		2	2	2
●	3	3		3	3	3		3	3	3
4	4	4		●	4	4		4	4	4
5	5	5		5	●	5		5	5	5
6	6	6		6	6	●		6	6	6
7	7	7		7	7	7		●	●	7
8	8	8		8	8	8		8	8	●
9	9	9		9	9	9		9	9	9

**Grid 10** is labeled “STUDENT ID NUMBER.”

All SHSAT test-takers should write their student ID number in Grid 10. You will find this number on your Admission Ticket for the test. In the boxes in Grid 10, write your nine-digit student ID number. Below each box, fill in the circle containing the same numeral as the box. (See the example to the left.)

curve. Scaled scores are on a scale that is common to all test forms, making it possible to compare these scores directly. The composite score is the sum of the verbal and mathematics scaled scores. The composite score is used to determine admission to a Specialized High School.

### ▶▶▶ STUDENT NOTIFICATION

Schools will receive information indicating student test results for those students who filed a New York City High School Admissions Application. You must have a High School Admissions Application on file to obtain your SHSAT score. This includes any private or parochial school students who may **only** be applying to the Specialized High Schools. **Students who did not file a High School Admissions Application will not be notified.** Students offered seats must indicate acceptance of the school to which they were selected by returning the signed letter to their guidance counselor.

Once students accept an offer to a school, they must remain in that school for a minimum of one year. The Specialized High Schools are prepared to provide whatever assistance students need to succeed. Parents/guardians of students who want to transfer must make a transfer request in writing and participate in a guidance conference before a transfer can be approved. **Students whose transfer is approved will be transferred to another high school, but not to another Specialized High School. (If a student feels that the Specialized High School is not a comfortable “fit,” that student is encouraged to apply for a tenth grade seat through the High School Admissions Process.)**

### ▶▶▶ REVIEW PROCEDURES

After the schools, students, and parents/guardians are informed of the results, parents/guardians accompanied by their child may review the student’s answer sheet by requesting an appointment with a representative from the Office of Assessment. Appointments may be arranged by writing to the Office of Assessment, SHSAT Review, 52 Chambers Street, Room 309, New York, New York 10007. **The request must be sent by certified mail with proof of delivery and post-marked no later than April 1, 2012.** An appointment date will be arranged within approximately four weeks of receipt of the letter. Copies of answer sheets are not available for distribution but will be reviewed at the scheduled appointment.

## Discovery Program

As stated in the State law, the Specialized High Schools may sponsor a Discovery Program to give disadvantaged students of demonstrated high potential an opportunity to participate in the Specialized High School program. The Office of Student Enrollment will determine the Specialized High Schools sponsoring a Discovery Program. Students will be notified if they are eligible to apply no earlier than May 2012.

### To be eligible, the student must:

1. have scored below and close to the lowest qualifying score on the SHSAT. Eligible scores will vary from year to year and will be based on seat availability; and
2. be certified as disadvantaged by his/her middle school according to the following criteria:
  - a. attend a Title 1 school and be from a family whose total income is documented as meeting federal income eligibility guidelines established for school food services by the NYS Department of Agriculture, effective July 1, 2011; or
  - b. be receiving assistance from the Human Resources Administration; or
  - c. be a member of a family whose income is documented as being equivalent to or below Department of Social Services standards; or
  - d. be a foster child or ward of the state; or
  - e. initially have entered the United States within the last four years and live in a home in which the language customarily spoken is not English; and
3. be recommended by his/her local school as having high potential for the Specialized High School program.

**Once notified of eligibility, families should meet with the school counselor to discuss the Discovery Program application. Documentation supporting student eligibility must be attached to the recommendation form submitted on behalf of the student by the middle school.** Not

all students recommended can be accepted into the Discovery Program. Those students who are successful in meeting the demands of the summer program will be granted an offer to the school sponsoring the Discovery Program. Those students who are not successful will attend the school to which they had previously been assigned. If you have questions, speak to your counselor.



The Specialized High Schools Admissions Test (SHSAT) assesses knowledge and skills. These skills consist of the ability to comprehend English prose, to think through a verbal problem in order to reach a reasoned conclusion based on given information, and the ability to use problem-solving skills in mathematics. The test measures knowledge and skills you have gained over the years. Keeping up with your schoolwork throughout the year is the best possible preparation.

## ▶▶▶ BEFORE TEST DAY

▶ **The best way to improve your verbal skills is to read many books and articles.** This helps you expand your vocabulary and improve your comprehension. While reading, ask yourself: What is the main point? What can be deduced? Why does the author use certain words? Is this article well written?

▶ **Knowing what to expect on the test and having some practice in test taking is beneficial.** This handbook describes each part of the test and contains two sample tests to use as practice. Each sample test contains questions from previous tests and has been updated to match the 2011 tests as closely as possible. A list of correct answers is provided for each test, along with explanations.

▶ **It is helpful to simulate the actual testing situation.** You will have two and a half hours to complete the test. During your practice test, how you allot the time between the verbal and mathematics sections is up to you. You may start on either section. It is recommended that you do not spend more than 75 minutes on either section. You may return to one section if you have time remaining after finishing the other section. Mark your answers on the answer sheet provided in this handbook.

▶ **After you complete the practice test, check your answers against the list of correct answers.** Read the explanations of the correct answers to see the kinds of mistakes you may have made. Did you read too quickly and misunderstand the question? Did you make careless errors in computation? Did you choose answers that were partially correct, but were not the best answers? Were many of your wrong answers guesses? You also should check to see whether there is a pattern to your errors. For example, did you get all the main idea questions wrong?

▶ **Put this handbook away for a few days, and then take the second sample test, following the same procedure.** Be aware that how well you do on these sample tests is not a predictor of your score on the actual test. However, these tests will give you an idea of what to expect when taking the SHSAT.

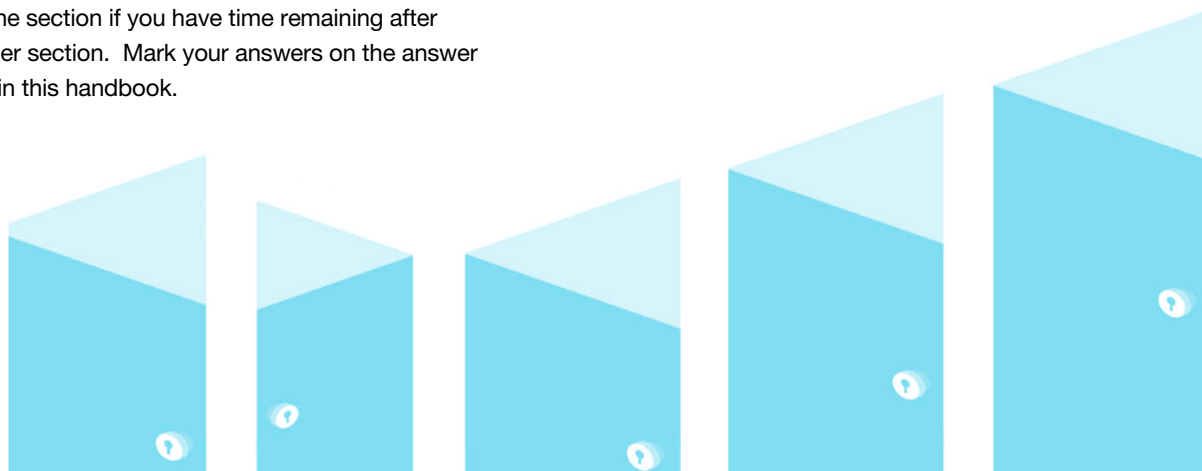

## ▶▶▶ DAY OF THE TEST

▶ **The night before the test, remember to get a good night's sleep.** Remember to bring your signed Admission Ticket with you to your assigned test site, including your ranked choices of Specialized High Schools indicated on the back of the Ticket. Arrive at your assigned test site on time. Wear comfortable clothes and bring a watch to keep track of the time. Make sure that you have several sharpened Number 2 pencils and an eraser that erases cleanly. Do not bring calculators, other computation aids, or electronic devices including cell phones, beepers, pagers, mp3 players, cameras, or devices that have image-capturing capabilities.

▶ **Plan your time.** Be aware of the total number of questions and the amount of time you have to complete the test. Work carefully, but keep moving at a comfortable pace and keep track of the time. Listen carefully to your test proctor and all instructions regarding time.

▶ **Read the instructions carefully.** Be sure you understand the task before marking your answer sheet. For each question, read all the choices before choosing one. Many questions ask for the best answer; it is important to compare all the choices to determine the choice that best answers the question.

▶ **Mark your answers carefully.** This is a machine-scored test, and you can lose credit by marking the wrong answer bubble or marking the answers to two questions on the same line. Make sure the number on the answer sheet matches the number of the question in your test booklet. To change an answer, erase the original mark completely. If two bubbles are filled in for a question, that question will be scored as incorrect. You may write in your test booklet to solve verbal or mathematics problems, but remember that only answers recorded on the answer sheet will be counted. Avoid making stray pencil marks on your answer sheet.

▶ **Make an educated guess when you do not know the answer to a question.** Do this by eliminating the answer choice(s) that are definitely wrong, and then choose one of the remaining answers.

▶ **If you finish before time is up, go back over your work** to make sure that you followed instructions, did not skip any questions, and did not make careless mistakes.

▶ **There is no penalty for a wrong answer.** Your score is based on the number of correct answers marked on the answer sheet. Therefore, omitting a question will not give you an advantage, and wrong answers will not be deducted from your right answers. Fill in any blanks when the time limit is almost up.

▶ **Be considerate of other students during the test.** Do not chew gum or make noises or movements that would be distracting to others.

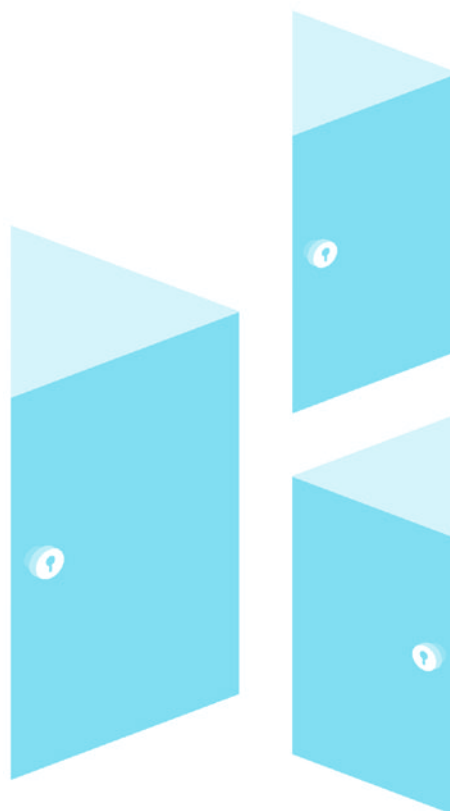

▶▶▶ SCRAMBLED PARAGRAPHS

The scrambled paragraph portion of the test measures your ability to organize written material according to the sequence of ideas and/or cues provided by transitional words and phrases. There are five paragraphs, each consisting of six sentences. The first sentence is provided, with the remaining five presented in random order. You are to arrange the sentences in the author’s original order using cues contained in the sentences. Only one arrangement of each set of sentences will form a well-organized, cohesive, grammatically correct paragraph. **Each correctly ordered paragraph is worth double the value of a question in any other section of the test.**

The sentences contain words and phrases that help to identify the flow of ideas from one sentence to the next, perhaps describing a procedure or tracing a historical event. The sentences may also provide grammatical cues as to how to construct the paragraph. For example, the pronoun “she” may refer to someone mentioned in a previous sentence. Transitional words such as “although” and “however” also provide cues about how the sentences relate to one another.

As you put the sentences in order, it may help to write the correct position of each sentence in the blank to the left. For example, write “2” next to the sentence that you think

follows the first sentence, “3” next to the sentence you think follows “2,” and so on.

Read **Example 1**. After reading all the sentences, you should have an idea of what the paragraph is about. Now go back to the given sentence and determine which sentence should come next. The given sentence states that scientists have “long known” that chimpanzees use tools. Sentence Q, with its opening phrase “more recently” creates a contrast with the given sentence. Q also makes a transition from the given sentence, from chimps’ use of tools for one purpose (food gathering and preparation) to their use of tools for “other purposes.”

U follows Q because U names the individual chimp (Kalunde) and adds the information that Kalunde had the flu. R continues the reference to Kalunde’s illness by describing his symptoms—cough and congestion. S presents the result of this congestion: Kalunde had to breathe through his mouth, which made eating difficult. T shows how Kalunde used a tool—a twig or plant stem—to clear his congestion, which concludes the paragraph. QURST has made a paragraph that is logically and grammatically correct.

QRUST might look appealing, but its transition from Q to R is poor. Q does not say anything about an illness, nor does it name the chimp, yet R refers to “the afflicted Kalunde,” as though Kalunde had already been mentioned, and describes

**Example 1**

Scientists have long known that chimpanzees have the ability to invent and use tools for the purpose of gathering and preparing food.

- \_\_\_\_\_ Q. However, more recently, researchers have observed a Tanzanian mountain chimpanzee demonstrate that chimps are also capable of inventing tools for other purposes.
- \_\_\_\_\_ R. The afflicted Kalunde suffered from a hacking cough and severely congested nasal passages.
- \_\_\_\_\_ S. This congestion forced Kalunde to breathe through his mouth, so he needed to clear his nasal passages in order to eat.
- \_\_\_\_\_ T. On four separate occasions, researchers observed Kalunde accomplish this goal by inserting a twig or plant stem into his nose, thus stimulating his reflex to sneeze.
- \_\_\_\_\_ U. These researchers were studying Kalunde, who, like many other chimps in his group, had a case of the dry-season flu.

**Example 1**

The second sentence is	●	Ⓡ	Ⓢ	Ⓣ	Ⓤ
The third sentence is	Ⓚ	Ⓡ	Ⓢ	Ⓣ	●
The fourth sentence is	Ⓚ	●	Ⓢ	Ⓣ	Ⓤ
The fifth sentence is	Ⓚ	Ⓡ	●	Ⓣ	Ⓤ
The sixth sentence is	Ⓚ	Ⓡ	Ⓢ	●	Ⓤ



his symptoms. The chimp’s illness is not introduced until the following sentence (U). The resulting paragraph is poorly organized.

QUSTR is also incorrect. When R, which describes Kalunde’s flu symptoms, is placed last, the paragraph becomes disjointed. The previous sentence (T) has said that Kalunde accomplished his goal of clearing his nasal passages after using a tool. R describes Kalunde’s condition **before** he used his tool, so it should appear earlier in the paragraph, as it does in the correct order (QRST).

▶▶▶ LOGICAL REASONING

This section consists of 10 questions that assess your ability to reason logically, using the facts, concepts, and information presented. **You must guard against jumping to conclusions that are not warranted from the information given.** There are different types of questions: figuring out codes, determining the relative positions of things or people, identifying correct assumptions, and drawing valid conclusions.

The most important strategy is to read the information carefully and make no assumptions that are not supported by the given information. Certain words must be read carefully. For example, **between** cannot be assumed to mean **between and right next to**; other things may be between these two objects as well. The same may be true of words such as **above, below, before, and after.**

Another good strategy is to look for information that is definitely stated, such as, “The red box is the largest,” or “Jane is not standing next to Erik.” This information makes it easier to determine the relative relationships.

For **Example 2**, draw a diagram to help you determine the order in which the planes departed. Statement 2 contains definite information about the Washington plane, so add that to the diagram:

1st	
2nd	
3rd	Washington
4th	
5th	

The remaining planes fly to Boston, Philadelphia, Cleveland, and Denver. Statement 3 says that the Denver plane left immediately after the Cleveland plane. (That means no planes departed between the Cleveland and Denver planes.) There are two possible orders, shown below:

1st	Cleveland		
2nd	Denver		
3rd	Washington	<b>OR</b>	Washington
4th			Cleveland
5th			Denver

The information in Statement 1 helps you determine which possible order is correct. It says that the Boston plane departed earlier than the Cleveland plane. That could not happen in the first possible order, so the second possible order must be correct. Because statement 1 also says that the Boston plane departed later than the Philadelphia plane, the complete order of departure must be:

1st	Philadelphia
2nd	Boston
3rd	Washington
4th	Cleveland
5th	Denver

The question asks how many planes left **between** the departures of the Boston and Denver planes. The answer is two (the planes departing for Washington and Cleveland).

**Example 2**

Exactly five planes departed from an airport, one at a time.

- 1) The Boston plane departed later than the Philadelphia plane, but earlier than the Cleveland plane.
- 2) The Washington plane departed third.
- 3) The Denver plane left immediately after the Cleveland plane.

How many planes left between the departures of the Boston plane and the Denver plane?

- A. 0
- B. 1
- C. 2
- D. 3
- E. Cannot be determined from the information given.

To answer **Example 3** correctly, it is important to understand the relationships among the members of the three musical groups. According to the question, every member of the jazz band is also a member of the orchestra. Draw a diagram to illustrate this relationship:

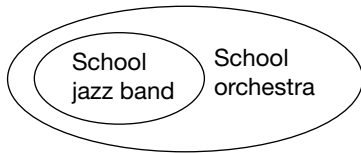

Some members of the choir are also members of the orchestra. The question says that Patrick is a member of exactly two of these groups, but it does not specify which groups. He could be in the jazz band and the orchestra, or he could be in the orchestra and the choir. He cannot be in the jazz band and the choir because membership in the jazz band implies membership in the orchestra, which adds up to memberships in three musical groups, not two.

Read each option and evaluate whether it **must** be true, based on the information given. Option F must be true; if Patrick is in the jazz band, then his second group is the orchestra, not the choir. The other options may or may not be true, but we cannot conclude that any of them **must** be true. Option H looks appealing, but it has changed the information given in the question. “Every member of the school jazz band is also a member of the school orchestra” does not mean “Every member of the school orchestra is also a member of the school jazz band.”

When the question involves a code, as in **Example 4**, do not solve for all parts of the code. Solve only those parts that relate

**Example 3**

Every member of the school jazz band is also a member of the school orchestra. Some members of the school choir are also members of the school orchestra. Patrick is a member of exactly two of these musical groups.

Based only on the information above, which of the following **must** be true?

- F. If Patrick is in the school jazz band, he is not in the school choir.
- G. If Patrick is in the school orchestra, he is not in the school choir.
- H. If Patrick is in the school orchestra, he must be in the jazz band.
- J. All members of the school orchestra are in at least two of these musical groups.
- K. All members of the school choir are in at least two of these musical groups.

to the question. Read the directions carefully. The letters in a sentence may or may not appear in the same order as the words they represent in that sentence. For example, in the first sentence, the first letter (L) may or may not represent the first word (Michelle).

In **Question 1**, the word “ships” appears only in the fourth sentence, so its corresponding letter must appear only in the fourth sentence. Letters Y and X (Options A and C) appear only in the fourth sentence. Is it possible to determine which letter represents the word “ships”? No, because the fourth sentence also contains another word, “Ivan,” that does not appear in any other sentence. It is impossible to determine which letter represents “ships” and which letter represents “Ivan.” Thus the correct answer is Option E, “Cannot be determined from the information given.” The letters N and W (Options B and D) appear in the fourth sentence, but they can

**Example 4**

Questions 1 and 2 refer to the following information.

In the code below, (1) each letter always represents the same word, (2) each word is represented by only one letter, and (3) in any given sentence, the letters may or may not be presented in the same order as the words.

L      W      Q      P      R      means  
 “Michelle paints planes and birds.”

Z      V      R      U      N      means  
 “Stuart draws cars and dogs.”

L      V      P      T      R      means  
 “Jesús paints cars and planes.”

Y      X      R      N      W      means  
 “Ivan draws birds and ships.”

1. Which letter represents the word “ships”?  
 A. Y  
 B. N  
 C. X  
 D. W  
 E. Cannot be determined from the information given.
2. Which word is represented by the letter V?  
 F. draws  
 G. paints  
 H. cars  
 J. and  
 K. planes



be ruled out because N also appears in the second sentence, and W also appears in the first sentence.

In **Question 2**, the letter V appears in the second and third sentences, but not in the first and fourth sentences. Find a word that also appears only in the second and third sentences. The word is “cars,” which is Option H. The other options cannot be correct. The letter V appears in the same position as “draws” in the second sentence and “paints” in the third sentence, but that does not mean it represents either word. In fact, the word “draws” also appears in the fourth sentence, and “paints” also appears in the first sentence, so neither word can be represented by the letter V. The word “and” (Option J) appears in all four sentences, so it can be ruled out. The word “planes” appears in the first and third sentences, so the letter V cannot represent that word.

▶▶▶ **READING**

This section measures your ability to read and comprehend English prose. There are five passages with six questions each. Each passage is 400 to 500 words long. The subjects include short biographies, discussions of historical events, descriptions of scientific phenomena, brief essays on art or music, discussions with a point of view, and human interest stories. There are no fictional passages.

For each passage, one question will always assess your understanding of the main idea of the passage. Other questions will ask about factual details and inferences that can be drawn.

You may read the questions first, but do not attempt to answer the questions without reading the passage. It is also unwise to

**Example 5**

Mary Cassatt defied tradition, family, and public opinion to become one of the most celebrated artists of the United States. Born in 1845, the daughter of a wealthy Pittsburgh banker, Cassatt spent several years of her childhood with her family in Europe. As she grew older, she gave up a life of ease to choose a path that at the time was almost impossible for a woman to follow. In 1861, while many of her friends were entering the social world of the upper classes, Cassatt was beginning her studies at the Pennsylvania Academy of Fine Arts. After four years, however, she felt stifled by the rigid curriculum. Against her father's wishes, she decided to return to Europe to study painting.

Cassatt spent several years, mainly in France and Italy, immersing herself in the works of great European painters of the past. Finally, in 1872, she settled in Paris permanently. There, Cassatt came to admire the work of the French Impressionists, a group of “outsiders” that included Degas, Monet, and Renoir. Unlike mainstream artists who produced the dark, polished, and detailed paintings favored by traditionalists and critics, these artistic revolutionaries applied pigment to the canvas in small dabs of pure color to achieve an illusion of light. Works painted in this manner presented not

photograph-like detail but a softer focus that conveyed a highly personalized impression.

This new movement inspired Cassatt. Discarding the traditional European style, she adopted the luminous tones of the impressionists. Particularly interested in the human figure, Cassatt began creating pastels of groups of women—on outings in the park, having tea, and so forth. In 1879, Edgar Degas invited her to exhibit with the impressionists, and her paintings were included in four of their next five shows. Cassatt and Degas admired each other's work and a loyal friendship developed. It was Degas who first suggested the mother-child theme that became the hallmark of Cassatt's later work.

Throughout her years in Europe, Cassatt kept in touch with her wealthy friends in the United States, introducing them to impressionist art. Many of the excellent collections of impressionist paintings in this country are to a great extent the result of her influence. As a woman and as an American, Cassatt stood virtually alone among the impressionist painters. Since her death in 1926, the work of the “Impressionist from Pennsylvania” has been avidly sought by collectors.



skim the passage instead of reading it carefully; you are likely to make inaccurate assumptions if you base them on only a few words or a short phrase. Often, the correct answer requires combining information from different parts of the passage. Since there will always be a question asking what the passage is about, try to formulate the answer by the time you have finished reading the passage. Likewise, try to answer each question before reading the choices. Then look at the choices to see which is closest to your answer. If none seems to be your answer, read the question again. You may reread the passage before you choose your answer.

Be wary of choices that are too broad or too narrow. Ask yourself whether the question requires you to draw a conclusion or inference from statements in the passage or simply to identify a restatement of the facts.

Base your answers only on the information presented in the passage. Do not depend solely on your prior knowledge of the topic. Enough information will be given for you to arrive at the correct answer.

### Example 5 continued...

- Which of the following best tells what this passage is about?
  - the barriers faced by women artists
  - the mother-child theme in Cassatt's work
  - why Cassatt is considered an early feminist
  - Cassatt's development as an artist
  - a brief history of impressionism
- Why did Cassatt leave the Pennsylvania Academy of Fine Arts?
  - Her father wanted her to study in Europe.
  - She felt the program there limited her creativity.
  - She did not want to enter Pittsburgh society.
  - She wanted to study with the French Impressionists.
  - She wished to rejoin her family.
- What prompted Cassatt to begin using the mother-child theme in her work?
  - It was an appropriate subject for a beginning artist.
  - It was a favorite theme of great European painters of past centuries.
  - It was suggested to her by another artist.
  - It was a common theme in the late nineteenth century.
  - It was favored by the critics.
- Which of the following best describes Cassatt as a young woman, before 1865?
  - interested in fashion and social standing
  - an independent thinker
  - friend to many French Impressionists
  - a painter in the impressionist style
  - a successful artist in her own right
- How was Cassatt unusual among impressionist painters?
  - Her painting style created the illusion of light.
  - She was befriended by Degas.
  - She managed to remain in the artistic mainstream of her day.
  - Her paintings have gained in value and popularity.
  - She was an American woman.
- In what way does the writer suggest that Cassatt influenced art collections in the United States?
  - She was an avid art collector in her own right.
  - She preferred to paint pastels of women and children.
  - She showed impressionist art to her wealthy American friends.
  - She settled in Paris permanently.
  - She exhibited regularly with the impressionists.

**▶ Question 1**

In Reading, the first question will always ask for the general theme of the passage. The correct answer must encompass the main points without being overly broad. Options A and B are details, not the main theme. Option E, “a brief history of impressionism,” is too broad. The passage focuses on only one impressionist painter, Mary Cassatt. Option C looks attractive, and while Cassatt is depicted as an independent and confident woman, which might be considered traits of a feminist, that term is not used in the passage and requires an inference that is not supported by the passage. Option D is best. The phrase “development as an artist” includes Cassatt’s background, education, artistic style, subject matter, and influence on the art world.

**▶ Question 2**

The answer to this question is found directly in the reading passage (lines 14-15): “she felt stifled by the rigid curriculum.” “Stifled” in this sense means repressed or held back. Option G restates this idea. Option F is not true (Cassatt’s father did not want her to study in Europe), and Option H, while a true statement, does not explain why she left her studies. Cassatt had not yet decided to study with French Impressionists (Option J), so that cannot be the reason. Option K is not mentioned.

**▶ Question 3**

The mother-child theme in Cassatt’s work is discussed in lines 45-48. It was first suggested by Edgar Degas, a fellow artist, which is Option C. The other options are not mentioned in the passage.

**▶ Question 4**

The question asks for a description of Cassatt before 1865. Cassatt began her studies at the Pennsylvania Academy of Fine Arts in 1861. Four years later, in 1865, she left the academy to study in Europe. Option F cannot be correct; she was never interested in fashion and social standing. Options H, J, and K are descriptive of dates much later than 1865. Option G, “an independent thinker,” best describes the young woman who left the social world of the upper classes and returned to Europe against her father’s wishes.

**▶ Question 5**

This question requires you to read all of the options and choose the best one. Option A was true of all impressionists, not just Cassatt. The passage provides no evidence that her friendship with Degas made her unusual among impressionist painters (Option B). Option C is not true; by joining the impressionists (called “outsiders” in line 24), she left, not remained in, the artistic mainstream of her day. Option D is true of many artists, so it is not what made Cassatt unusual. Option E is the best answer. Lines 55-57 state, “As a woman and as an American, Cassatt stood virtually alone among the impressionist painters.” In other words, she was unusual as a successful female American impressionist painter.

**▶ Question 6**

Art collections in the United States are mentioned in the last paragraph. Cassatt introduced impressionist art from Europe to her wealthy American friends, thus influencing many of them to buy it. Option H best summarizes this idea. None of the other options explain how Cassatt influenced art collections in the United States.



This section includes arithmetic, algebra, probability, statistics, and geometry problems. The technical terms and general concepts in these test questions can be found in the New York State Education Department **Mathematics Resource Guide with Core Curriculum**. Most problems involve application of topics covered in the **Core Curriculum**; however, since the **Core Curriculum** is just an outline, not all details of a topic are provided. Consequently, some aspects of a question may not be mentioned. As one of the purposes of this test is to identify students who will benefit from an education at a Specialized High School, the SHSAT contains many questions that require using mathematical ability to respond creatively to novel situations. The NYSED Mathematics Resource Guide with Core Curriculum can be downloaded from the New York State Education Department website: [www.nysed.gov](http://www.nysed.gov).

## TIPS FOR TAKING THE MATHEMATICS SECTION OF THE SHSAT

**T**o improve your mathematics skills, choose a mathematics textbook and solve five to ten problems every day. Do both routine and difficult problems. Routine problems reinforce basic mathematical facts. More challenging problems help you understand mathematics concepts better. Do not give up if you cannot complete some of the problems. Skip them and move on. You may be able to solve them after you have learned more. Also, do not limit yourself to problems that test what you have learned in your mathematics class only. Go beyond what you have been taught and try new types of problems.

▶ You must **know the meanings of technical terms** such as “parallel” and “perpendicular” that are appropriate to your grade level, as well as the customary symbols that represent those terms. You also need to **know various formulas** such as those for the perimeter and area of different figures. You can find these technical terms, symbols, and formulas in your mathematics textbook. These terms, symbols, and formulas will **NOT** be given in the test booklet. Practice using them until you know them by heart.

▶ Read each problem carefully and work out the answer on scrap paper or in your test booklet. **Do not calculate on your answer sheet.**

▶ Most problems should be done by **working out the answer**. This is more efficient than trying out the options to see which one fits the question. The only exception is when you are explicitly asked to look at the options, as in, “Which of the following is an odd number?”

▶ If the question is a word problem, it often is helpful to **express it as an equation**. When you obtain an answer, look at the choices listed. If your answer is included among the choices, mark it. If it is not, reread the question and solve it again.

▶ The incorrect choices are often answers that people get if they misread the question or make common computational errors. For this reason, it is unwise to solve a problem in your head while looking at the possible choices. It is too easy to be attracted to a wrong choice.

▶ If your answer is not among the answer choices, write your answer in a different form. For example,  $10(x + 2)$  is equivalent to  $10x + 20$ .

▶ You may draw figures or diagrams for questions that do not have them.

▶ Some questions ask you to combine a series of simple steps. Take **one step at a time**, using what you know and what the question tells you to do.

▶ The sample tests in this handbook are Grade 8 forms. If you are taking the Grade 9 test, work the problems on pages 109-111 as well. These problems cover topics that are introduced in the Core Curriculum for Grade 8.

**EXAMPLE 6**

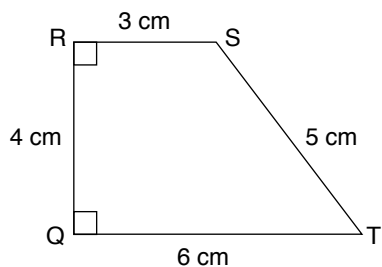

What is the area of trapezoid QRST?

- A. 2 sq cm
- B. 18 sq cm
- C. 24 sq cm
- D. 72 sq cm
- E. 360 sq cm

▶ **IN EXAMPLE 6**, use the formula for the area of a trapezoid:

$$\text{Area} = \frac{1}{2} \cdot \text{height} \cdot (\text{sum of the bases})$$

From the figure, we know that the height of QRST is 4 cm and that one base is 6 cm, while the other base is 3 cm.

$$\text{Thus: } A = \frac{1}{2}(4)(3 + 6) = \frac{1}{2}(4)(9) = 18 \text{ sq cm}$$

**EXAMPLE 7**

Kendra traveled on a train for 8 hours and 12 minutes at an average speed of 110 kilometers per hour. How far did she travel?

- F. 120 km
- G. 170 km
- H. 891 km
- J. 892 km
- K. 902 km

▶ **IN EXAMPLE 7**, first convert 12 minutes into a fraction of an hour and add that to the 8 hours:

$$\frac{12}{60} = \frac{1}{5} \text{ hour} + 8 \text{ hours}$$

So Kendra's total travel time was  $8\frac{1}{5}$  hours. Multiply her travel time by 110 kilometers per hour to calculate the distance she traveled:

$$8\frac{1}{5} \cdot 110 = \frac{41}{5} \cdot 110 = 902 \text{ km}$$

**EXAMPLE 8**

The length of the border between the United States and Canada is approximately  $2.5 \times 10^6$  meters. What is this length in kilometers?

- A. 250 km
- B. 2,500 km
- C. 25,000 km
- D. 2,500,000 km
- E. 2,500,000,000 km

▶ **IN EXAMPLE 8**, start by converting  $2.5 \times 10^6$  from scientific notation to standard form:

$$2.5 \times 10^6 = 2,500,000 \text{ meters}$$

To change from meters to kilometers, divide by 1,000:  
 $2,500,000 \div 1,000 = 2,500 \text{ km}$

**EXAMPLE 9**

If the mean of 6, 8, 10, and  $x$  is 8, what is  $x$ ?

- F. 4
- G. 8
- H. 12
- J. 16
- K. 32

▶ **IN EXAMPLE 9**, set up an equation to calculate the mean and solve for  $x$ :

$$\frac{6 + 8 + 10 + x}{4} = 8$$

$$24 + x = 32$$

$$x = 8$$

**▶ TAKING THE SAMPLE TESTS**

Now you are ready to try sample test Form A. Begin by carefully reading the Directions on pages 28 and 29 and filling out side 1 of the Answer Sheet on page 30. For Form A, use side 2 of the Answer Sheet (page 31). When you are ready for Form B, use the Answer Sheet on page 69. You may tear out pages 31 and 69 to make it easier to mark your answers.

# NEW YORK CITY PUBLIC SCHOOLS

## 2011 Specialized High Schools

### ADMISSIONS TEST

#### GENERAL DIRECTIONS

##### Identifying Information

Turn to Side 1 of the answer sheet. Line 1 says, “I am well enough to take this test and complete it. I understand that once I break the seal of the test booklet, I will not be eligible for a make-up test. I am a New York City resident and a Grade 8 student taking a Grade 8 test. I understand that a student who is not a New York City resident, who takes the test more than once in a given school year, or who takes the test at the wrong grade level will be disqualified from acceptance to any of the specialized high schools.” Sign your name in the space following the word “signature.” Do not print your name. **Notify the proctor immediately if you are ill or should not be taking this test. Do not sign the statement or begin the test. Return your answer sheet to the proctor.**

On **Line 2**, print the name and borough of the school where you are now enrolled. On **Line 3**, print today’s date, using the numbers of the month, the day, and the year. On **Line 4**, print your birth date with the number of the month first, then the number of the day, then the last two digits of the year. For example, a birth date of March 1, 1997, would be 3-1-97.

In **Grid 5**, print the letters of your first name, or as many as will fit, in the boxes. Write your name exactly as you did on the application. If you have a middle initial, print it in the box labeled “MI.” Then print your last name, or as much as will fit, in the boxes provided. Below each box, fill in the circle that contains the same letter as the box. If there is a space in your name, or a hyphen, fill in the circle under the appropriate blank or hyphen.

Make **dark marks** that **completely fill the circles**. If you change a mark, be sure to erase the first mark completely.

**Grid 6** is for your choice of specialized high schools. If Grid 6 is not marked correctly, your admission to a specialized high school will be affected because your admission is based on the score you attain and the order in which you rank your school preferences. Therefore, carefully copy the order in which you ranked the schools on your admission ticket onto Grid 6.

**Fill in one and only one circle for each school for which you wish to be considered.** You may make as few as one or as many as eight choices. To increase your chances of being assigned to one of the specialized high schools, you are encouraged to make more than one choice. You **must** fill in a first choice school. Do not fill in a school more than once. Do not fill in the same school for each choice. Fill in only one circle in a row and only one circle in a column.

In **Grid 7**, fill in the circle that identifies your sex.

**Grid 8** is labeled “TEST BOOKLET LETTER AND NUMBER.” In the boxes, copy the letter and numbers shown in the upper-right corner of your test booklet. Below each box, fill in the circle containing the same letter or number as the box.

For **Grid 9**:

1. Print the name of the school where you are now enrolled in the space at the top of the grid.
2. In the boxes marked “SCHOOL CODE,” print the six-digit code that identifies your school and fill in the circle under the corresponding number or letter for each digit of the school code. (You can find your school code on your admission ticket. If it is not there, you or the proctor should look in the Feeder School List under the borough in which your school is located to find the code for your school.)
3. If you attend a private or parochial school, fill in the circle marked “P”.
4. Under “BOROUGH OF SCHOOL,” fill in the circle for the borough in which your school is located.
5. Under “TYPE OF SCHOOL,” fill in the circle next to “NYC Public” if you attend a public school; fill in the circle next to “Private or Parochial” if you attend a private or parochial school.

**DO NOT OPEN THIS BOOKLET  
UNTIL YOU ARE TOLD TO DO SO  
TURN YOUR BOOKLET OVER TO THE BACK COVER**

## GENERAL DIRECTIONS, continued

**Grid 10** is labeled “STUDENT ID NUMBER.” All SHSAT test-takers should write their student ID number in Grid 10. The student ID number is found on your admission ticket. In the boxes, print your nine-digit student ID number. Below each box, fill in the circle containing the same number as in the box.

**Grid 11** asks for your date of birth. Print the first three letters of the month in the first box, the number of the day in the next box, and the last two digits of the year in the last box. Then fill in the corresponding circles.

Now review this page to make sure you have completed all lines and grids correctly. Review each column to see that the filled-in circles correspond to the letters or numbers in the boxes above them.

Turn your answer sheet to Side 2. Print your test booklet letter and numbers; your name, first name **first**; and your home address and phone number in the spaces provided.

### Marking Your Answers

Be sure to mark all your answers in the row of answer circles corresponding to the question number printed in the test booklet. Use a Number 2 pencil. If you change an answer, be sure to erase it completely. **You may write in your test booklet to solve verbal or mathematics problems, but your answers must be recorded on the answer sheet in order to be counted.** Be careful to avoid making any stray pencil marks on your answer sheet.

Each question has only one correct answer. If you mark more than one circle in any answer row, that question will be scored as incorrect. Select the **best** answer for each question. Your score is determined by the number of questions you answered correctly. **It is to your advantage to answer every question, even though you may not be certain which choice is correct.** See the example of correct and incorrect answer marks at the top of the next column.

SAMPLE ANSWER MARKS						
1	(A)	(B)	(C)	(D)	●	RIGHT
2	✓	(G)	(H)	(J)	(K)	WRONG
3	(A)	<del>(B)</del>	(C)	(D)	(E)	WRONG
4	(F)	(G)	⊖	(J)	(K)	WRONG
5	(A)	(B)	●	●	(E)	WRONG

### Planning Your Time

You have 150 minutes to complete the entire test. How you allot the time between the Verbal and Mathematics sections is up to you. **If you begin with the Verbal section, you may go on to the Mathematics section as soon as you are ready. Likewise, if you begin with the Mathematics section, you may go on to the Verbal section as soon as you are ready.** It is recommended that you do not spend more than 75 minutes on either section. If you complete the test before the allotted time (150 minutes) is over, you may go back to review questions in either section.

Work as rapidly as you can without making mistakes. Don't spend too much time on a difficult question. Return to it later if you have time.

Students must remain for the entire test session.

### Example 1

**DIRECTIONS:** Solve the problem. Find the **best** answer among the answer choices given.

- E1.** If four ice cream cones cost \$2.00, how much will three ice cream cones cost?

- A. \$0.50
- B. \$1.00
- C. \$1.25
- D. \$1.50
- E. \$1.75

AA

EXAMPLE ANSWER					
E1.	(A)	(B)	(C)	●	(E)

**DO NOT OPEN THIS BOOKLET UNTIL  
YOU ARE TOLD TO DO SO**







Student's First Name (please print) \_\_\_\_\_

Student's Last Name (please print) \_\_\_\_\_

Student's Home Address      Apartment      Borough      ZIP Code      Home Telephone Number

**PART 1 VERBAL**

**SCRAMBLED PARAGRAPHS**

**Paragraph 1**

- The second sentence is    Q    R    S    T    U
- The third sentence is    Q    R    S    T    U
- The fourth sentence is    Q    R    S    T    U
- The fifth sentence is    Q    R    S    T    U
- The sixth sentence is    Q    R    S    T    U

**Paragraph 2**

- The second sentence is    Q    R    S    T    U
- The third sentence is    Q    R    S    T    U
- The fourth sentence is    Q    R    S    T    U
- The fifth sentence is    Q    R    S    T    U
- The sixth sentence is    Q    R    S    T    U

**Paragraph 3**

- The second sentence is    Q    R    S    T    U
- The third sentence is    Q    R    S    T    U
- The fourth sentence is    Q    R    S    T    U
- The fifth sentence is    Q    R    S    T    U
- The sixth sentence is    Q    R    S    T    U

**Paragraph 4**

- The second sentence is    Q    R    S    T    U
- The third sentence is    Q    R    S    T    U
- The fourth sentence is    Q    R    S    T    U
- The fifth sentence is    Q    R    S    T    U
- The sixth sentence is    Q    R    S    T    U

**Paragraph 5**

- The second sentence is    Q    R    S    T    U
- The third sentence is    Q    R    S    T    U
- The fourth sentence is    Q    R    S    T    U
- The fifth sentence is    Q    R    S    T    U
- The sixth sentence is    Q    R    S    T    U

**LOGICAL REASONING**

- |      |   |   |   |   |      |   |   |   |   |
|------|---|---|---|---|------|---|---|---|---|
| 11 A | B | C | D | E | 33 A | B | C | D | E |
| 12 F | G | H | J | K | 34 F | G | H | J | K |
| 13 A | B | C | D | E | 35 A | B | C | D | E |
| 14 F | G | H | J | K | 36 F | G | H | J | K |
| 15 A | B | C | D | E | 37 A | B | C | D | E |
|      |   |   |   |   | 38 F | G | H | J | K |
| 16 F | G | H | J | K | 39 A | B | C | D | E |
| 17 A | B | C | D | E | 40 F | G | H | J | K |
| 18 F | G | H | J | K | 41 A | B | C | D | E |
| 19 A | B | C | D | E | 42 F | G | H | J | K |
| 20 F | G | H | J | K | 43 A | B | C | D | E |
|      |   |   |   |   | 44 F | G | H | J | K |

**READING**

- |      |   |   |   |   |      |   |   |   |   |
|------|---|---|---|---|------|---|---|---|---|
| 21 A | B | C | D | E | 45 A | B | C | D | E |
| 22 F | G | H | J | K | 46 F | G | H | J | K |
| 23 A | B | C | D | E | 47 A | B | C | D | E |
| 24 F | G | H | J | K | 48 F | G | H | J | K |
| 25 A | B | C | D | E | 49 A | B | C | D | E |
| 26 F | G | H | J | K | 50 F | G | H | J | K |
| 27 A | B | C | D | E |      |   |   |   |   |
| 28 F | G | H | J | K |      |   |   |   |   |
| 29 A | B | C | D | E |      |   |   |   |   |
| 30 F | G | H | J | K |      |   |   |   |   |
| 31 A | B | C | D | E |      |   |   |   |   |
| 32 F | G | H | J | K |      |   |   |   |   |

**PART 2 MATHEMATICS**

**MATHEMATICS PROBLEMS**

- |      |   |   |   |   |      |   |   |   |   |      |   |   |   |   |       |   |   |   |   |
|------|---|---|---|---|------|---|---|---|---|------|---|---|---|---|-------|---|---|---|---|
| 51 A | B | C | D | E | 66 F | G | H | J | K | 81 A | B | C | D | E | 96 F  | G | H | J | K |
| 52 F | G | H | J | K | 67 A | B | C | D | E | 82 F | G | H | J | K | 97 A  | B | C | D | E |
| 53 A | B | C | D | E | 68 F | G | H | J | K | 83 A | B | C | D | E | 98 F  | G | H | J | K |
| 54 F | G | H | J | K | 69 A | B | C | D | E | 84 F | G | H | J | K | 99 A  | B | C | D | E |
| 55 A | B | C | D | E | 70 F | G | H | J | K | 85 A | B | C | D | E | 100 F | G | H | J | K |
| 56 F | G | H | J | K | 71 A | B | C | D | E | 86 F | G | H | J | K |       |   |   |   |   |
| 57 A | B | C | D | E | 72 F | G | H | J | K | 87 A | B | C | D | E |       |   |   |   |   |
| 58 F | G | H | J | K | 73 A | B | C | D | E | 88 F | G | H | J | K |       |   |   |   |   |
| 59 A | B | C | D | E | 74 F | G | H | J | K | 89 A | B | C | D | E |       |   |   |   |   |
| 60 F | G | H | J | K | 75 A | B | C | D | E | 90 F | G | H | J | K |       |   |   |   |   |
| 61 A | B | C | D | E | 76 F | G | H | J | K | 91 A | B | C | D | E |       |   |   |   |   |
| 62 F | G | H | J | K | 77 A | B | C | D | E | 92 F | G | H | J | K |       |   |   |   |   |
| 63 A | B | C | D | E | 78 F | G | H | J | K | 93 A | B | C | D | E |       |   |   |   |   |
| 64 F | G | H | J | K | 79 A | B | C | D | E | 94 F | G | H | J | K |       |   |   |   |   |
| 65 A | B | C | D | E | 80 F | G | H | J | K | 95 A | B | C | D | E |       |   |   |   |   |

# SAMPLE TEST, FORM A

## PART 1 — VERBAL

*Suggested Time — 75 Minutes*

45 QUESTIONS

---

### SCRAMBLED PARAGRAPHS

PARAGRAPHS 1-5

**DIRECTIONS:** In this section, arrange each group of sentences to create the best paragraph. The first sentence for each paragraph is given; the remaining five sentences are listed in random order. Choose the order for these five sentences that will create the **best** paragraph, one that is well-organized, logical, and grammatically correct. Each correctly ordered paragraph is worth **double** the value of a question in any other section of the test. No credit will be given for responses that are only partially correct.

To keep track of your sentence order, use the blanks to the left of the sentences. For example, write “2” next to the sentence you think follows the first sentence, write “3” next to the sentence you think follows “2,” and so on. You may change these numbers if you decide on a different order. When you are satisfied with your sentence order, mark your choices on your answer sheet.

---

#### Paragraph 1

What song is sung more often than any other song in the United States, with the exception of the national anthem?

- \_\_\_\_\_ **Q.** Surprisingly, neither the composer nor the lyricist had ever even been to a baseball park at the time the song was written in 1910.
- \_\_\_\_\_ **R.** The answer is “Take Me Out to the Ballgame,” probably the best-known song ever written about the sport traditionally called “America’s national pastime.”
- \_\_\_\_\_ **S.** Albert von Tilzer, the lyricist, eventually went to a ballgame in the 1920s.
- \_\_\_\_\_ **T.** Twenty years after Tilzer went, composer Jack Norworth saw the Brooklyn Dodgers defeat the Chicago Cubs in his first Major League game.
- \_\_\_\_\_ **U.** It is usually sung during the seventh-inning stretch of a baseball game.

CONTINUE ON TO THE NEXT PAGE ►

---

## Paragraph 2

For centuries, the Indigenous people of Australia have used musical rituals to map out a network of invisible pathways covering much of Australia.

- \_\_\_\_\_ **Q.** Researchers believe that the singers communicate these features to their listeners through the use of commonly understood patterns of notes and rhythms.
- \_\_\_\_\_ **R.** Songlines are so detailed and specific that a listener can identify geographic features: rivers, mountains, deserts, and sand dunes.
- \_\_\_\_\_ **S.** It is thought that such patterns enable members of different clans, who speak different languages, to decode each other’s songlines.
- \_\_\_\_\_ **T.** These rituals, called “songlines,” describe the terrain and landmarks along a traveler’s route.
- \_\_\_\_\_ **U.** However, the opportunities to study songlines are disappearing rapidly, as the Indigenous way of life is changed by Western civilization.

---

## Paragraph 3

The now-abandoned settlement of Nan Madol, located on a coral reef off the shore of the Micronesian island of Pohnpei, was built over a thousand years, beginning around A.D. 500.

- \_\_\_\_\_ **Q.** The new building materials—some pieces were twenty feet long and weighed nearly six tons—were transported to Pohnpei on rafts.
- \_\_\_\_\_ **R.** The ancestors would build a great fire around a column, then pour cool seawater on it, causing it to split along natural fracture lines.
- \_\_\_\_\_ **S.** Then they were placed in their present positions by means of hibiscus fiber ropes and the inclined trunks of coconut palm trees.
- \_\_\_\_\_ **T.** The islanders say that their ancestors obtained the stone from quarries on a nearby island, where large basalt columns were formed naturally by the cooling of molten lava.
- \_\_\_\_\_ **U.** The structures of Nan Madol are remarkable for the sheer size of the stone “logs” or columns used to create the retaining walls of the offshore community, and anthropologists must rely on information provided by local people to learn how Nan Madol was built.

CONTINUE ON TO THE NEXT PAGE ►

---

**Paragraph 4**

Macaws, a type of parrot found in South America, are among the largest and most beautiful birds in the world.

- \_\_\_\_\_ **Q.** Scientists believe that the birds may eat the clay in order to counteract poisons contained in some of these fruit seeds.
- \_\_\_\_\_ **R.** The birds do not appear to eat clay to satisfy hunger; they ingest it even when fruit seeds, their favorite foods, are available.
- \_\_\_\_\_ **S.** Like many other parrot species, they are very intelligent as well, yet some of their behaviors have baffled scientists.
- \_\_\_\_\_ **T.** This theory is supported by the fact that the birds eat more clay in the dry season, when less-poisonous food is scarce.
- \_\_\_\_\_ **U.** For example, macaws regularly flock to riverbanks to eat the clay found in river mud.

---

**Paragraph 5**

To the earliest European traders, Africa seemed to be loosely organized into tribal societies, without any great centers of wealth or learning.

- \_\_\_\_\_ **Q.** He described a thriving metropolis with great universities and dozens of private libraries.
- \_\_\_\_\_ **R.** Unfortunately, by the nineteenth century raids by neighboring tribes had made Timbuktu a shadow of its former self.
- \_\_\_\_\_ **S.** This impression began to change in the fifteenth century, as Europeans traveled inland into western Africa.
- \_\_\_\_\_ **T.** In 1470, an Italian merchant named Benedetto Dei traveled to Timbuktu and confirmed these stories.
- \_\_\_\_\_ **U.** The travelers told tales of an enormous city, known as Timbuktu, on the southern edge of the Sahara Desert, where the markets were crowded with goods and gold was bought and sold.

CONTINUE ON TO THE NEXT PAGE ►

---

# LOGICAL REASONING

## QUESTIONS 11-20

**DIRECTIONS:** Read the information given and choose the **best** answer to each question. Base your answer **only on the information given**.

In a logical reasoning test, certain words must be read with caution. For example, “The red house is **between** the yellow and blue houses” does not necessarily mean “The red house is **between and next to** the yellow and blue houses”; one or more other houses may separate the red house from the yellow house or from the blue house. This precaution also applies to words such as **above, below, before, after, ahead of, and behind**.

---

11. Any student who receives a grade lower than B- on the February report card is not permitted to play on a sports team in the spring.

Based only on the information above, which of the following **must** be true?

- A. Every student who received all A's on the February report card plays on a sports team in the spring.
- B. No student who plays on a sports team in the spring received a grade of C+ or lower on the February report card.
- C. The best athletes also get the highest grades.
- D. Students who do not play on sports teams in the spring received higher grades in February than those who do.
- E. Students who play on sports teams spend a lot of time studying.

- 
12. Five students used the telephone in the gym office at separate times on Wednesday.

- 1) Steve used it earlier than Raymond.
- 2) Elise used it earlier than Raymond, but later than Ahmed.
- 3) Tiffany used it last.

Who used the telephone first?

- F. Steve
- G. Elise
- H. Ahmed
- J. Either Elise or Ahmed, but it is not possible to determine which one.
- K. Either Ahmed or Steve, but it is not possible to determine which one.

13. Five dolls are arranged according to size, with the largest doll first and the smallest doll last. Each doll is a different color.

- 1) The red doll is next to and smaller than the blue doll.
- 2) The purple doll is not next to the yellow doll.
- 3) The green doll is larger than the blue doll.
- 4) The purple doll is smaller than the red doll.

What is the position of the red doll?

- A. first
- B. second
- C. third
- D. fourth
- E. Cannot be determined from the information given.

CONTINUE ON TO THE NEXT PAGE ►

- 
- 14.** Some teachers went to the lecture on how not to be boring. None of the teachers left the lecture early.

Based only on the information above, which of the following statements **must** be true?

- F.** If Miriam left the lecture early, then she is not a teacher.  
**G.** If François is not a teacher, he was not at the lecture.  
**H.** Lu-San went to the lecture, so she is a teacher.  
**J.** If Peter was not a teacher, then he left the lecture early.  
**K.** Tom did not go to the lecture, so he is not a teacher.
- 

- 15.** Four bikes are parked in a bike rack.

- 1) The blue bike is parked on the extreme left.
- 2) The yellow bike is next to the red bike.
- 3) The green bike is between the yellow bike and the blue bike.
- 4) Paul's bike is between the blue bike and the red bike.

Based only on the information above, which of the following **must** be true?

- A.** Paul's bike is green.  
**B.** The yellow bike is between the red bike and the green bike.  
**C.** Paul's bike is yellow.  
**D.** The red bike is next to the green bike.  
**E.** The color of Paul's bike cannot be determined.

---

Questions 16 and 17 refer to the following information.

In the code below, (1) each letter always represents the same word, (2) each word is represented by only one letter, and (3) in any given sentence, the letters may or may not be presented in the same order as the words.

L            S    Q    M    T    means  
"Sherbet is cold and sweet."

T            Q    V    N    R    means  
"Chili is spicy and hot."

Q            X    W    T    L    means  
"Lemonade is cold and tart."

P            T            M    V    means  
"Hot chocolate is sweet."

- 16.** Which letter represents the word "and"?

- F.** T  
**G.** L  
**H.** M  
**J.** Q  
**K.** Cannot be determined from the information given.

- 17.** Which word is represented by the letter V?

- A.** chili  
**B.** spicy  
**C.** hot  
**D.** sweet  
**E.** Cannot be determined from the information given.

CONTINUE ON TO THE NEXT PAGE ►



- 
18. When Tomas wears his white shirt, he also wears a tie. When he wears a tie, he also wears his black shoes.

Based only on the information above, which of the following statements is a valid conclusion?

- F. When Tomas wears his black shoes, then he is wearing his white shirt.
- G. Tomas wears his black shoes only when he is wearing a tie.
- H. When Tomas wears his white shirt, then he is also wearing his black shoes.
- J. If Tomas is not wearing his white shirt, then he is not wearing a tie.
- K. If Tomas is not wearing a tie, then he is not wearing his black shoes.

- 
19. Six houses are next to one another on one side of Park Street. The houses are lettered L, M, N, P, Q, and R, consecutively.

- 1) The two houses that have fenced yards are immediately next to one another.
- 2) Three houses have porches.
- 3) None of the houses with a porch is next to one another.
- 4) No house has both a fenced yard and a porch.

Based only on the information above, which of the following **must** be true?

- A. Houses L and R have porches.
- B. House N has a porch.
- C. House P has a porch.
- D. Houses P and Q have fenced yards.
- E. Either House M or House N has a fenced yard, but it is not possible to determine which one.

- 
20. Most people in the Skydiving Club are not afraid of heights. Everyone in the Skydiving Club makes three parachute jumps a month.

Based only on the information above, which of the following statements **must** be true?

- F. Skydivers are less afraid of heights than are non-skydivers.
- G. A person must make three parachute jumps a month in order to join the Skydiving Club.
- H. Some people who are afraid of heights make three parachute jumps a month.
- J. Most people who are not afraid of heights are in the Skydiving Club.
- K. Every skydiver makes at least one parachute jump a month.

CONTINUE ON TO THE NEXT PAGE ►

# READING

## QUESTIONS 21-50

**DIRECTIONS:** Read each passage below and answer the questions following it. Base your answers **only on information contained in the passage**. You may reread a passage if you need to. Mark the **best** answer for each question.

Wolves communicate with one another in a variety of ways, including scent marking, posture, and body movements. For centuries, however, it has been the howling of wolves that has stirred the emotions and imaginations of people. Researchers have spent years trying to understand why wolves howl, occasionally simulating wolf howls themselves to determine how the wolves will respond.

Howling apparently serves several purposes. Wolves howl to keep track of one another's location or to reestablish contact, especially when roaming in unfamiliar territory. Howling also serves to reinforce the cohesion of the pack. Wolves howl to assemble the members before a hunt and to celebrate success after a hunt. In addition, howling may be a way to mark the boundaries of a pack's territory, in the same way that some birds use birdsong to warn other birds away.

A group howling session may continue for as long as an hour, and an individual howl may last up to 20 seconds, followed by a pause. Each wolf, like each human being, has a distinctive voice, and each wolf in a pack recognizes the howls of the other members. Like people, young wolves have higher-pitched voices than their elders. They are less likely to initiate a howling session, but they join in quickly when another wolf begins to howl. When wolves howl in chorus, they do not howl in unison; rather, each wolf joins in on another note.

The image of the lone wolf howling at the moon may fascinate, but it is the exception, not the rule. A lone wolf will sometimes howl, perhaps looking for a mate or other

wolves to begin a new pack, but howling is predominantly a social activity. Much howling, therefore, may be an expression of celebration, fellowship, or sheer good spirits. The evidence suggests that wolves howl, at least in part, because they enjoy it.

However, theories about the motivations for animal behavior must carefully consider the evidence. For example, some observers have claimed that wolves fake their howling in order to fool other wolves. They maintain that a young wolf can bluff its way out of trouble by lowering the pitch of its voice to sound like an older animal. Or, a chorus of four wolves can sound like nearly a dozen and thus intimidate potential enemies. But no independent evidence has been found to support these notions. Such behaviors, if they occurred, might indeed fool people, but wolf hearing is so discriminating that it is unlikely that wolves themselves would be fooled. Besides, wolves learn early that silence is often the best defense in times of danger.

21. Which of the following best tells what this passage is about?
- A. people's reactions to wolf howls
  - B. how wolves fake their howls
  - C. animal behavior in the wild
  - D. how young wolves learn to howl
  - E. purposes of wolf howling

CONTINUE ON TO THE NEXT PAGE ►

- 22.** Which of the following statements is **not** supported by the passage?
- F.** Howling communicates territorial boundaries.
  - G.** Wolves communicate only within their own pack.
  - H.** Howling sessions sometimes last up to an hour.
  - J.** Wolves sometimes celebrate by howling.
  - K.** Wolves howl both before and after a hunt.
- 23.** According to the passage, how is birdsong similar to howling?
- A.** It can be used to track another animal's location.
  - B.** It may be used to find a mate.
  - C.** It may be used to indicate the boundaries of a territory.
  - D.** It can be used to advertise the location of food.
  - E.** It is often an expression of communal good feelings.
- 24.** According to the passage, which of the following is the most likely reason that wolves howl in chorus?
- F.** to celebrate a successful hunt
  - G.** to begin a new pack
  - H.** to obscure their specific location
  - J.** to attract members of the opposite sex
  - K.** to keep other wolves away from their food
- 25.** The examples in the last paragraph are given by some observers to suggest that wolves can deceive their enemies about their
- A.** vulnerability.
  - B.** territorial boundaries.
  - C.** specific location.
  - D.** lack of a mate.
  - E.** search for a new pack.
- 26.** Why do some researchers doubt that wolves can fake their howling in order to fool other wolves in time of danger?
- F.** A chorus of four wolves can sound like many more.
  - G.** Wolves can fool people, so they can also fool other wolves.
  - H.** A young wolf can lower its voice to sound like an older animal.
  - J.** Wolves always howl when they are in danger.
  - K.** Wolf hearing is too keen to confuse the voices of other wolves.

CONTINUE ON TO THE NEXT PAGE ►

Imagine living in a society where ordinary people could be punished for what they choose to read and write. For much of the twentieth century, such a closed society existed in Russia and the rest of the Soviet Union. The Soviet government tried to dominate its citizens' activities and ideas by controlling the information that they received. Government censors examined books, films, and newscasts and banned anything they considered objectionable. They censored criticism of the Soviet government, news from the outside world, and anything that complimented Soviet enemies.

The Soviet government's strict censorship made life tremendously difficult for writers. Most worried that they were being watched by the government's secret police. Despite the harsh laws, small groups of writers dodged state censorship through an underground, or secret, publishing network that produced works called *samizdat*. The name *samizdat* came from the Russian words for "self" and "publish." For many writers, *samizdat* offered the only outlet for their intellectual and creative expression. To produce *samizdat*, an author passed a typed or handwritten text to a second person, who made a handwritten or typed copy. The original was returned to the author, while the copies were passed to other members of the network. The works were unsigned or signed with false names.

At first, *samizdat* focused mainly on literature, such as poetry and novels. By the late 1950s, *samizdat* circles were distributing political material, such as letters to the government, political essays, and trial transcripts. By the mid-1960s, the *samizdat* network produced sophisticated political news, debate, and analysis.

The great Russian novelist Boris Pasternak had his work published as *samizdat*. Like other writers, he feared that an appearance of disloyalty to the Soviet state would bring a knock at his door in the middle of the night. His classic novel, *Doctor Zhivago*,

was smuggled out of the Soviet Union for publication in Western countries in 1956; in Russia, it appeared only as *samizdat*. Pasternak won the Nobel Prize in Literature in 1958, but the government forced him to refuse the prize. Soviet authorities also blocked publication of the work of Anna Akhmatova, one of Russia's greatest poets. Her work was banned until 1952 because censors felt she did not sufficiently praise the Soviet government. Akhmatova was kept out of public life and the official Writers' Union. She composed her poetry in private, and her works were available only as *samizdat*.

Through the 1960s and '70s, Russian writers used *samizdat* networks to circulate banned or politically risky material. By the late 1980s, computers became available in scientific research facilities, and underground writers began using the computers to store and circulate texts. Censorship was officially abolished in 1989, shortly before the breakup of the Soviet Union, leading to a publishing boom. Works by previously banned authors were published, and the *samizdat* networks quickly faded into history.

27. Which of the following best tells what this passage is about?
- A. two Russian authors, Boris Pasternak and Anna Akhmatova
  - B. the poetry published in the Soviet Union during the twentieth century
  - C. the role of a free press in a free society
  - D. censorship in the Soviet Union and the underground system that arose in response
  - E. the reasons for banning authors who criticized the Soviet government

CONTINUE ON TO THE NEXT PAGE ►

28. Which of the following is most likely an example of material circulated in the earliest phase of samizdat?
- F. a letter protesting a writer's imprisonment
  - G. a true account of life in the secret police
  - H. a short story
  - J. a list of political prisoners
  - K. an article from a foreign newspaper
29. The phrase "a knock at his door in the middle of the night" (lines 47-48) most likely refers to a visit by
- A. Boris Pasternak.
  - B. the secret police.
  - C. a member of the Nobel Prize committee.
  - D. a participant in the samizdat network.
  - E. a political exile.
30. According to the passage, how did the use of computers influence samizdat publishing?
- F. The content of samizdat materials became exclusively technical.
  - G. Scientific research was published through samizdat networks.
  - H. Computers gave underground writers access to Russian stores.
  - J. Computers made the distribution of samizdat material more efficient.
  - K. Computers made identification of samizdat authors easier for the secret police.
31. What is the most likely reason that samizdat materials were unsigned or signed with false names?
- A. to allow the materials to be smuggled outside the Soviet Union
  - B. to protect the writer from punishment
  - C. to shield the identities of members of the secret police
  - D. to undermine the trustworthiness of the materials
  - E. to prevent the materials from being copied
32. After 1989, "samizdat networks quickly faded" (lines 75-76) for which of the following reasons?
- F. The networks were no longer necessary after censorship was abolished.
  - G. The works produced by the networks could not compete with works published in Western countries.
  - H. Samizdat was successfully banned by government censors.
  - J. The networks were replaced by the use of computers.
  - K. Opposition to the government went deeper underground than before.

CONTINUE ON TO THE NEXT PAGE ►

If you have ever watched someone fall on the ice, you've seen slipperiness at work. But have you wondered what makes ice slippery, or why skates or skis glide across ice so easily? The answer might seem obvious: ice is smooth. Yet smoothness in itself does not explain slipperiness. Imagine, for example, skating on a smooth surface of glass or sheet metal.

Surprisingly, scientists do not fully understand why ice is slippery. Past explanations of slipperiness have focused on friction and pressure. According to the friction theory, a skate blade rubs across the ice, causing friction. The friction produces heat, melting the ice and creating a slippery, microscopically thin layer of water for the skate to glide on. The friction theory, however, cannot explain why ice is slippery even when someone stands completely motionless, creating no friction.

The pressure theory claims that pressure from a skate blade melts the ice surface, creating a slippery layer of water. The water refreezes when the pressure is lifted. Science textbooks typically cite this explanation, but many scientists disagree, claiming that the pressure effect is not great enough to melt the ice. Nor can the pressure theory explain why someone wearing flat-bottomed shoes—which have a greater surface area than skate blades and thus exert less pressure per square inch—can glide across the ice or even go sprawling.

During the 1990s, another theory found acceptance: the thin top layer of ice is liquid, or “liquid-like,” regardless of friction or pressure. This notion was first proposed more than 150 years ago by physicist Michael Faraday. Faraday’s simple experiment illustrates this property: two ice cubes held against each other will fuse together. This happens, Faraday explained, because liquid on the cubes’ surfaces froze solid when the surfaces made contact.

Faraday’s hypothesis was overlooked, in part because scientists did not have the means to detect molecular structures.

However, technological advances during recent decades allow scientists to measure the thin layer on the surface of the ice. For example, in 1996, a chemist at Lawrence Berkeley Laboratory shot electrons at an ice surface and recorded how they rebounded. The data suggested that the ice surface remained “liquid-like,” even at temperatures far below freezing. Scientists speculate that water molecules on the ice surface are always in motion because there is nothing above them to hold them in place. The vibration creates a slippery layer of molecules. According to this interpretation of the Lawrence Berkeley Laboratory experiments, the molecules move only up and down; if they also moved side to side, they would constitute a true liquid. Thus it could be said that people are skating on wildly vibrating molecules!

The phenomenon of a slippery liquid-like surface is not limited to ice, although ice is the most common example. Lead crystals and even diamond crystals, made of carbon, also show this property under certain temperature and pressure conditions.

33. Which of the following best tells what this passage is about?
- A. theories about how people learn to skate
  - B. how ice changes from a solid to a liquid
  - C. answers to the question of what makes ice slippery
  - D. the discoveries of Michael Faraday
  - E. the processes of freezing and melting

CONTINUE ON TO THE NEXT PAGE ►

- 34.** What is the most likely reason that the author mentioned lead and diamond crystals in the last paragraph?
- F.** to point out that solids other than ice have slippery surfaces
  - G.** to suggest that ice, lead, and diamonds are composed of the same materials
  - H.** to cast doubt on Faraday’s theory of slipperiness
  - J.** to suggest that scientists shoot electrons at lead and diamond surfaces
  - K.** to suggest new uses for slippery substances
- 35.** According to Faraday, why do two ice cubes fuse when held together?
- A.** Friction causes the ice to melt and refreeze.
  - B.** The warmer ice cube melts the colder ice cube.
  - C.** The liquid layers on their surfaces freeze.
  - D.** The vibrations of the molecules on their surfaces increase.
  - E.** Their surface areas are perfectly smooth.
- 36.** What is the most likely reason that the author mentioned the 1996 experiment at Lawrence Berkeley Laboratory?
- F.** to provide evidence about the surface of ice
  - G.** to illustrate the weaknesses of scientific technology
  - H.** to show how Faraday tested his theory
  - J.** to suggest that the ice surface was solid, not liquid
  - K.** to explain why ice cubes freeze together
- 37.** According to researchers at the Lawrence Berkeley Laboratory, why is the surface of ice “liquid-like” rather than “liquid”?
- A.** because electrons rebound from the ice surface
  - B.** because the molecules vibrate only up and down
  - C.** because the ice surface is wet
  - D.** because the ice surface is slipperier than a liquid surface
  - E.** because the ice surface is frozen solid
- 38.** According to the passage, which of the following undermines the friction theory of slipperiness?
- F.** a person wearing flat-bottomed shoes gliding across the ice
  - G.** two ice cubes fused together
  - H.** electrons bouncing off an ice surface
  - J.** a person trying to skate on a sheet of glass or sheet metal
  - K.** a person slipping while standing immobile on ice

CONTINUE ON TO THE NEXT PAGE ►



The African country of Zimbabwe took its name from the Shona word meaning “stone enclosures” or “venerated houses.” In fact, dozens of stone ruins are today scattered throughout Zimbabwe and other areas in southeastern Africa. One of these ruins, known as “Great Zimbabwe,” was once a fabled city that inspired tales that circulated throughout Europe. Where was this remarkable city, and who had built it? For centuries the mystery occupied the minds of explorers and treasure-seekers.

The first reports to Europeans of Great Zimbabwe were spread a thousand years ago by Arab traders sailing between the Middle East and the east coast of Africa. They told of the fabulous wealth of a mysterious stone city in the African interior. In their tales, that city became associated with their understanding of Middle Eastern history—with the Queen of Sheba, King Solomon, and his legendary gold mines, long since lost to the world. By the sixteenth century, Portuguese explorers regularly visited East Africa, searching for “King Solomon’s gold,” but they never found Great Zimbabwe. In 1552, a Portuguese historian, João de Barros, recorded a story told by the Arabs about a city with a “square fortress of masonry within and without, built of stones of marvelous size, and there appears to be no mortar joining them.”

In fact, Great Zimbabwe **was** a marvel. In one area, a massive wall, over thirty feet high and twenty feet thick, created a great enclosure. Another area contained a fortress-like series of walls, corridors, and steps built into the bluff above. Throughout the city, each stone was precisely fitted to the others without the use of mortar.

In the 1870s, a German geologist, Karl Mauch, was the first European to see Great Zimbabwe, by then in ruins. Mauch realized that he had “rediscovered” the fabled city from de Barros’s story. He jumped to the conclusion that Great Zimbabwe had been built by the Queen of

Sheba. British authorities sent a British journalist, Richard Hall, to Great Zimbabwe to investigate Mauch’s report. Archaeology was still in its infancy, and Hall, convinced that the structures had been built by ancient people from the Middle East, dug up and discarded archaeological deposits that would have revealed much about the true history of Great Zimbabwe. Later European excavations destroyed even more valuable evidence.

In the twentieth century, after excavating areas that had not been disturbed, David Randall-MacIver, a Scottish Egyptologist, and Gertrude Caton-Thompson, an English archaeologist, concluded that the ruins were unmistakably African in origin. Great Zimbabwe was most likely built during the fourteenth or fifteenth century by the ancestors of the present-day Shona people. Recent carbon-14 dating supports their conclusion. Great Zimbabwe was once home to an estimated 20,000 people, the center of a great Shona kingdom. Wealthy Shona kings traded their ivory and gold in coastal towns for other goods, thus accounting for the discovery of beads and other foreign wares in the ruins.

One mystery of Great Zimbabwe had been solved. Another mystery remains: why was the settlement at Great Zimbabwe abandoned, leaving the magnificent stone architecture to fall into ruins?

39. Which of the following best tells what this passage is about?
- A. a brief history of the nation of Zimbabwe
  - B. inaccuracies in the recording of African history
  - C. a comparison of Great Zimbabwe with other African archaeological sites
  - D. the true story of the Great Zimbabwe ruins
  - E. how Karl Mauch discovered Great Zimbabwe

40. With which of the following statements about Richard Hall's opinion regarding Great Zimbabwe would the author most likely agree?
- F. First impressions are generally accurate.
  - G. Preconceptions can cloud a person's judgment.
  - H. The history of a people can best be judged by looking at its present culture.
  - J. Advanced cultures developed first in the Middle East, then spread to the rest of the world.
  - K. Much of Middle Eastern culture was derived from the culture of the Shona people.
41. What was "one mystery of Great Zimbabwe" (line 77) that had been solved?
- A. why foreign wares were found in the ruins
  - B. why the settlement was abandoned
  - C. the source of the ivory and gold
  - D. why it was not discovered by Europeans until the 1870s
  - E. who had built it and when
42. Which of the following statements about the Shona people is best supported by the passage?
- F. They no longer exist as a distinct group.
  - G. They live along Africa's East Coast.
  - H. They are descendants of the people who built Great Zimbabwe.
  - J. They lived in the Middle East before settling in Africa.
  - K. They were once ruled by King Solomon and the Queen of Sheba.
43. Which of the following best illustrates the statement that "Archaeology was still in its infancy" (lines 51-52)?
- A. the stone buildings built without mortar
  - B. the abandonment of Great Zimbabwe
  - C. the conclusions of David Randall-MacIver and Gertrude Caton-Thompson
  - D. the discovery of beads and other foreign materials at Great Zimbabwe
  - E. the excavations conducted by Richard Hall

44. Which of the following best describes the relationship of Portuguese explorers to Great Zimbabwe?
- F. They searched for it but never found it.
  - G. They told Arab traders where to find it.
  - H. They found King Solomon's mines but didn't realize it.
  - J. They destroyed archaeological evidence about its history.
  - K. They were responsible for its abandonment.

CONTINUE ON TO THE NEXT PAGE ►

In 1903, Dr. H. Nelson Jackson, a Vermont doctor, was enjoying a vacation in California when he made a historic bet with a few friends. Jackson claimed that, though he was not a professional driver, he could cross the country by automobile. While driving cross-country is commonplace today, at the turn of the last century such a trip was unprecedented. Automobile routes in the northeastern United States were well maintained, and the number of highway miles was increasing rapidly. Most roads in the western states, however, were little more than rough wagon tracks.

Refusing any assistance from automobile manufacturers, Jackson and his driving partner, Sewell Crockett, left San Francisco and headed east, somewhat ironically reversing the earlier routes of the pioneers. Like those rugged settlers, the two men spent much of their time traveling on muddy trails over hazardous and rough terrain. Though their automobile, a 1903 Winston, performed well, they often encountered unexpected delays. No one had ever attempted a cross-country automobile trip before, and maps were quite unreliable. Often their trip was held up by an unanticipated canyon or a surging river that they had thought would be miles away.

Residents of some small towns had never seen an automobile, and when the Winston approached, many of them trembled in fear. The modern machine attracted so much attention that Jackson's bulldog Bud was given the responsibility of guarding the car from people who, enchanted by its novelty, were tempted to steal a shiny piece as a souvenir. In Idaho, after sinking embarrassingly into a shallow quicksand pit, Dr. Jackson had to ask for help from a farmer who pulled the "state-of-the-art" automobile out of the muck, using the team of horses from his wagon.

On July 26, Jackson and Crockett reached their destination, New York City, and drove down Fifth Avenue in Manhattan. They had completed their trip in sixty-three days,

traveling between 4,200 and 4,500 miles. Their cross-continental record was short-lived, however. By 1910, other drivers, benefitting from better driving conditions, had shortened the transcontinental crossing time to ten days. It may be that Jackson and Crockett played as much of a role in "opening up" the continent as did their predecessors who traveled in covered wagons.

45. Which of the following best tells what this passage is about?
- A. the reactions of people when they saw an automobile for the first time
  - B. a comparison of highways in the eastern and western United States
  - C. the hazards of travel in the early twentieth century
  - D. a history of automobile travel in the United States
  - E. a historic automobile trip by twentieth-century pioneers
46. Why did Jackson's automobile attract so much attention (lines 34-35)?
- F. An automobile was an uncommon sight in many areas.
  - G. It was the first automobile custom-built for long-distance travel.
  - H. People had never seen a pet dog traveling in an automobile.
  - J. Jackson was the first person to drive an automobile in the United States.
  - K. People had heard about the automobile sinking into the quicksand.
47. In line 37, the phrase "its novelty" refers to the novelty of the
- A. bulldog.
  - B. car.
  - C. small town.
  - D. residents.
  - E. journey.

48. What does the incident with the farmer and his horses show?
- F. The automobile would soon be the best method of transportation.
  - G. Jackson and Crockett occasionally needed help from others.
  - H. The theft of auto parts had caused the automobile to become stuck in the quicksand.
  - J. There were many quicksand pits in the West.
  - K. Older methods of transportation had many dangers.
49. What is the most likely reason that a cross-country automobile trip was shortened so dramatically by 1910?
- A. Jackson's hand-drawn maps showed how to make the journey.
  - B. The drivers in 1910 did not get stuck in quicksand.
  - C. The intervening seven years were a time of rapid progress in highway development.
  - D. Travelers in 1910 were more adventurous than Jackson.
  - E. Unlike Jackson, the drivers in 1910 were sponsored by automobile companies.
50. In the last sentence, the phrase "their predecessors" refers to
- F. the early settlers.
  - G. the first auto makers.
  - H. cross-country drivers in 1910.
  - J. the curious townspeople.
  - K. the friends of Jackson and Crockett.

CONTINUE ON TO THE NEXT PAGE ►

# PART 2 — MATHEMATICS

Suggested Time — 75 Minutes

50 QUESTIONS

## GENERAL INSTRUCTIONS

Solve each problem. Select the **best** answer from the choices given. Mark the letter of your answer on the answer sheet. You can do your figuring in the test booklet or on paper provided by the proctor. **DO NOT MAKE ANY MARKS ON YOUR ANSWER SHEET OTHER THAN FILLING IN YOUR ANSWER CHOICES.**

### IMPORTANT NOTES:

- (1) Formulas and definitions of mathematical terms and symbols are **not** provided.
- (2) Diagrams other than graphs are **not** necessarily drawn to scale. Do not assume any relationship in a diagram unless it is specifically stated or can be figured out from the information given.
- (3) Assume that a diagram is in one plane unless the problem specifically states that it is not.
- (4) Graphs are drawn to scale. Unless stated otherwise, you can assume relationships according to appearance. For example, (on a graph) lines that appear to be parallel can be assumed to be parallel; likewise for concurrent lines, straight lines, collinear points, right angles, etc.
- (5) Reduce all fractions to lowest terms.

51.

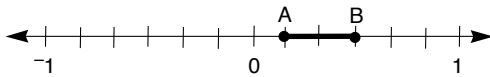

On the number line above, intervals are equally spaced, and point  $x$  lies in the interval AB. What are the lower and upper limits of all possible values of  $x$ ?

- A.  $\frac{1}{6}, \frac{1}{2}$
- B.  $\frac{1}{2}, \frac{5}{6}$
- C.  $\frac{1}{6}, \frac{5}{6}$
- D.  $-\frac{5}{6}, -\frac{1}{2}$
- E.  $-\frac{2}{3}, -\frac{1}{3}$

52.

Ms. Garcia determines math grades on the basis of 5 tests, each worth 100 points. An average of at least 80 points is needed for a grade of B. On the first 4 tests, Hilary scored 91, 72, 69, and 83. What is the lowest score she may receive on the final test and still earn a B?

- F. 80
- G. 82
- H. 84
- J. 85
- K. 86

53.

Three chains, each 14 feet in length, are linked end to end. Two longer chains of equal length are added to make a total length of 100 feet. What is the length of **one** of the longer chains?

- A. 29 ft
- B. 36 ft
- C. 42 ft
- D. 58 ft
- E. 72 ft

CONTINUE ON TO THE NEXT PAGE ►

- 
54. Suppose that the age of the earth is  $5.2 \times 10^9$  years, and the age of a particular artifact is  $1.3 \times 10^7$  years. How many times older than the artifact is the earth?

F.  $4.0 \times 10^{12}$   
G.  $4.0 \times 10^6$   
H.  $2.5 \times 10^6$   
J.  $2.5 \times 10^3$   
K.  $4.0 \times 10^2$

---

55. 
$$\frac{7 + n}{43 + n} = \frac{1}{3}$$

What is the value of  $n$  in the equation above?

A. 9  
B. 11  
C. 12  
D. 16  
E. 25

---

56. What is the prime factorization of 1,200?

F.  $2^2 \times 3 \times 5^2$   
G.  $2^3 \times 3 \times 5^2$   
H.  $2^4 \times 3 \times 5^2$   
J.  $2^4 \times 3^2 \times 5^2$   
K.  $2^4 \times 3^2 \times 5$

---

57. If  $x = y - 7$ , what is the value of  $3x - 3$  in terms of  $y$ ?

A.  $3y - 18$   
B.  $3y - 24$   
C.  $2y - 4$   
D.  $2y - 10$   
E.  $y - 10$

---

- 
58. Laura rode her bicycle at 15 miles per hour for 2 hours, and then at 12 miles per hour for 1 hour. What was her average speed for the entire ride?

F. 12 mph  
G. 13.5 mph  
H. 14 mph  
J. 15 mph  
K. 42 mph

---

59. Four friends are going to sit in a row on a bench to have their picture taken. In how many different orders can the four friends sit?

A. 4  
B. 6  
C. 8  
D. 12  
E. 24

---

60. For what value of  $m$  is  $\frac{5m - 3}{2 + m} = 4$ ?

(Note:  $m \neq -2$ .)

F. 14  
G. 11  
H. 8  
J. 7  
K. 5

---

61. What is the value of  $4x^2 + 5x - 8$ , if  $x = -3$ ?

A. -59  
B. -35  
C. 1  
D. 13  
E. 43

---

CONTINUE ON TO THE NEXT PAGE ►

62. If a rectangular room is 3 times as long as it is wide, and if the width is 8 feet, how many square feet of carpet are needed to cover the floor?

F. 24 sq ft  
G. 32 sq ft  
H. 72 sq ft  
J. 88 sq ft  
K. 192 sq ft

63. Jodi's class has between 30 and 41 students. Exactly 75% of the students in her class have red book bags, and exactly  $\frac{1}{6}$  of the students in her class do not have a book bag at all. How many students are in Jodi's class?

A. 32  
B. 34  
C. 36  
D. 38  
E. 40

64.

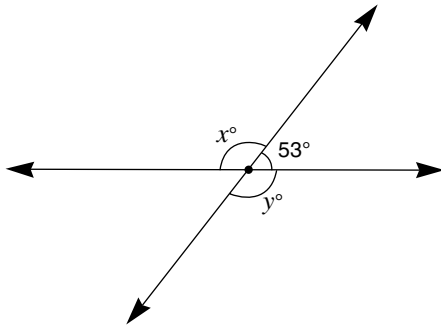

The figure above shows two intersecting lines. What is the sum of  $x$  and  $y$ ?

F. 53  
G. 74  
H. 106  
J. 127  
K. 254

65.  $N$ ,  $M$ , and  $T$  are integers.  
 $N + M$  is an odd number.  
 $M + T$  is an odd number.

Which of the following **must** be true?

A.  $N \times T$  is even.  
B.  $N \times T$  is odd.  
C.  $N + T$  is odd.  
D.  $N + T$  is even.  
E.  $N - T$  is odd.

66.  $\frac{4.5}{0.1} \times 0.22 =$

F. 0.99  
G. 1.99  
H. 9.9  
J. 99  
K. 990

67.  $(8 - 16) \div (-8 + 6)$

If the parentheses are removed from the above expression, how will the value of the expression change?

A. no change  
B. increase of 3  
C. increase of 7  
D. increase of 12  
E. increase of 16

68. If  $2x + 2y - 6 = 14$ , what is the value of  $x$  in terms of  $y$ ?

F.  $10 - y$   
G.  $10 - 2y$   
H.  $8 - y$   
J.  $8 - 2y$   
K.  $4 - y$

CONTINUE ON TO THE NEXT PAGE ►



69. A merry-go-round has 25 horses. Each horse is labeled consecutively with a letter from A to Y—the first horse is labeled A, the second horse is labeled B, and so on. A child walks around the merry-go-round, starting at horse A and continuing in alphabetical order, counting as she goes. She stops at the 337<sup>th</sup> horse. What is the letter of that horse?

- A. A
- B. J
- C. K
- D. L
- E. M

70. A 5-ounce bag of candies sells for \$1.50. At this rate, what would be the price of a 1-pound bag of candies? (Note: 1 lb = 16 oz.)

- F. \$0.30
- G. \$3.00
- H. \$3.60
- J. \$4.50
- K. \$4.80

71. In a salsa dance class, the ratio of women to men is 3:2. What percent of the students are women?

- A. 40%
- B. 60%
- C.  $66\frac{2}{3}\%$
- D. 75%
- E. 150%

72. How many integers between 75 and 105 have a remainder of 2 when divided by 15?

- F. 0
- G. 1
- H. 2
- J. 3
- K. 5

73. For what value of  $x$  is  $\frac{2(x + 1)}{3} = 1$ ?

- A. 0
- B.  $\frac{1}{2}$
- C. 1
- D. 2
- E.  $\frac{5}{2}$

74. A taxi company charges \$2.00 per ride plus \$0.30 for each  $\frac{1}{5}$  of a mile ridden. If a taxi ride costs \$20.00, how many miles long was the ride?

- F.  $6\frac{2}{3}$  mi
- G. 12 mi
- H.  $13\frac{1}{3}$  mi
- J. 20 mi
- K. 60 mi

75.

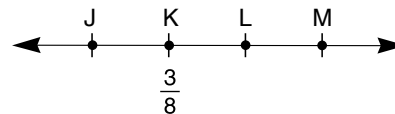

On the number line above,  $JK = 3\frac{1}{2}$ ,  $JM = 9\frac{3}{4}$ , and  $LM = 1\frac{1}{8}$ . What is the position of point L?

- A.  $5\frac{1}{8}$
- B.  $5\frac{1}{2}$
- C.  $6\frac{1}{4}$
- D.  $6\frac{5}{8}$
- E.  $8\frac{1}{4}$

CONTINUE ON TO THE NEXT PAGE ►

76. Shelby's rent is \$800 per month. Since she could not pay this month's rent when due, her landlord agreed to accept 40% of the rent on the first day of the month, another 25% of the original rent on the tenth, and the rest on the twentieth. How much rent must Shelby pay on the twentieth day?
- F. \$80  
 G. \$280  
 H. \$300  
 J. \$360  
 K. \$520

77. If  $x = -2$  and  $y = 3$ , what is the value of  $5x - 2xy$ ?
- A. -22  
 B. -2  
 C. 0  
 D. 2  
 E. 22

78.

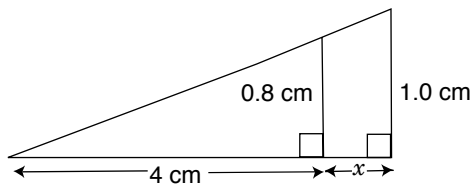

In the figure above, what is the value of  $x$ ?

- F. 1 cm  
 G. 1.2 cm  
 H. 3.2 cm  
 J. 4 cm  
 K. 5 cm
79. A nation has five types of coins: sinds, dalts, lorgs, harps, and plunks. A sind is worth four lorgs. Two plunks equal five dalts. Three harps are worth one plunk. Five sinds are worth two harps. Which coin is most valuable?
- A. sind  
 B. dalt  
 C. lorg  
 D. harp  
 E. plunk

80. Raoul is  $x$  years old now, and Phil is 8 years older than Raoul. In 2 years, Phil will be exactly twice as old as Raoul is then. How old is Raoul now?
- F. 3  
 G. 5  
 H. 6  
 J. 8  
 K. 10

81. If 1 quart of paint covers 100 square feet of wall, what is the **least** number of 1-quart cans of paint needed to completely cover two rectangular walls measuring 12 feet by 9 feet plus two additional rectangular walls measuring 10 feet by 9 feet?
- A. 1  
 B. 2  
 C. 3  
 D. 4  
 E. 5

82. If  $60 \div n = 24m$ , what is the value of  $nm$ ?
- F. 0.4  
 G. 2.5  
 H. 5.2  
 J. 36  
 K. 1,440

83. When positive integer  $p$  is divided by 7, the remainder is 3. When  $p$  is divided by 5, the remainder is 2. What is the **least** possible value of  $p$ ?
- A. 10  
 B. 12  
 C. 17  
 D. 38  
 E. 52

CONTINUE ON TO THE NEXT PAGE ►

84. The mean of twenty numbers is 42. If four of the twenty numbers have a mean of 50, what is the mean of the other sixteen numbers?
- F. 32  
G. 36  
H. 40  
J. 46  
K. 65

85.  $50 < x^2 < 65$   
 $17 < y^2 < 32$
- If  $x$  and  $y$  are positive integers, what is the value of  $xy$ ?
- A. 13  
B. 28  
C. 35  
D. 40  
E. 45

86.

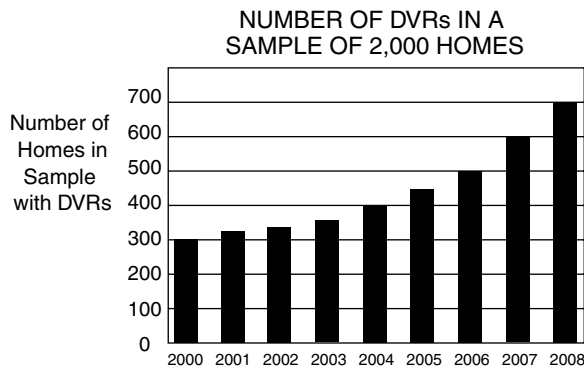

Based on the graph above, what was the first year in which at least 25 percent of the homes in the sample of 2,000 had DVRs?

- F. 2000  
G. 2001  
H. 2004  
J. 2006  
K. 2008

87. At a hotel, Jahmir exchanged 300 dollars and received 192 nobles. Based on that information, how many nobles are equal to 1 dollar? (Assume that there are no exchange fees.)
- A.  $\frac{3}{5}$   
B.  $\frac{16}{25}$   
C.  $\frac{4}{5}$   
D.  $\frac{16}{15}$   
E.  $\frac{25}{16}$

88. How many positive integers are between  $\frac{28}{3}$  and  $\frac{83}{5}$ ?
- F. 6  
G. 7  
H. 16  
J. 54  
K. 55

89. On a number line, points K and T are 12 units apart. Point M is the midpoint of  $\overline{KT}$ . Point W is the midpoint of  $\overline{MT}$  and is located at 5 on the number line. Which number below is a possible midpoint of  $\overline{KW}$ ?
- A. -1  
B. -0.5  
C. 0.5  
D. 1  
E. 4.5

CONTINUE ON TO THE NEXT PAGE ►

90. DISTANCE AND ALTITUDE OF TWO PLANES

	Distance of Plane from Airport at Time $t$	Altitude of Plane at Time $t$
Plane M	$(310 - 2t)$ miles	$(32,800 - 20t)$ feet
Plane N	$(3t + 235)$ miles	$(31,600 + 40t)$ feet

For the mid-flight time ( $t$ ) in minutes between 0 and 100, the altitudes of two planes and their distances from the airport are indicated in the table above. At the minute the planes are at the same distance from the airport, what is the difference between their altitudes?

- F. 25 ft
- G. 180 ft
- H. 300 ft
- J. 420 ft
- K. 3,300 ft

91.  $A_1A_2 + A_2A_3 + A_3A_4 + A_4A_5 + A_5A_6$

If  $A_k = \frac{1}{k}$  for any positive value of  $k$ , and  $k$  is a positive integer, what is the value of the expression above?

- A.  $\frac{1}{70}$
- B.  $\frac{1}{14}$
- C.  $\frac{5}{6}$
- D. 1
- E.  $\frac{29}{20}$

92. In a certain city there are 50,000 licensed drivers. If 40,000 of the licensed drivers wear glasses and 30,000 of the licensed drivers are over 30 years old, what is the smallest possible number of licensed drivers who **both** wear glasses and are over 30?

- F. 10,000
- G. 20,000
- H. 24,000
- J. 30,000
- K. 35,000

93.  $V = \frac{1}{3} \pi r^2 h$

In the volume formula shown above, if  $r$  is divided by 2 and  $h$  is doubled, what is the ratio of the new volume to the original volume?

- A. 1:4
- B. 1:2
- C. 1:1
- D. 2:1
- E. 4:1

94. If  $w < 0$  and if  $z > 0$ , which expression **must** be positive?

- F.  $w - z^2$
- G.  $z + w^2$
- H.  $z^2 \div w$
- J.  $z - w^2$
- K.  $w + z^2$

95.  $\frac{2x + 5}{x - 2}$

If  $0 \leq x \leq 5$ , how many integer values of  $x$  will make the above expression an integer?

- A. 0
- B. 1
- C. 2
- D. 3
- E. 4

96. On a coordinate system, the line segment joining the points (6, 8) and (12, 10) has the same midpoint as the line segment joining the points (8, 11) and ( $x$ , 7). What is the value of  $x$ ?

- F. 4
- G. 5
- H. 6
- J. 9
- K. 10

CONTINUE ON TO THE NEXT PAGE ►

---

**97.** Let  $\text{GCF}(x, y)$  represent the greatest common factor of  $x$  and  $y$ . If  $p$  is a positive **even** integer less than 11, for what value of  $p$  does  $\text{GCF}(p^2, 81)$  have the **greatest** value?

- A. 2
  - B. 4
  - C. 6
  - D. 8
  - E. 10
- 

**98.** A regular dodecagon has 12 equal sides and 12 equal angles. How many degrees are in each interior angle of a regular dodecagon?

- F.  $30^\circ$
  - G.  $150^\circ$
  - H.  $154^\circ$
  - J.  $168^\circ$
  - K.  $216^\circ$
- 

**99.** If the mean of  $w, x, y,$  and  $z$  is 60, and the mean of  $v, x, y,$  and  $z$  is 62, what is the value of  $v - w$ ?

- A. 2
  - B. 4
  - C. 6
  - D. 8
  - E. 10
- 

**100.** A goat is tied by a 6 meter rope to the outside corner of a square shed measuring 8 meters by 8 meters. What is the area of the surrounding grass on which the goat can graze?

- F.  $6\pi$  sq m
  - G.  $8\pi$  sq m
  - H.  $27\pi$  sq m
  - J.  $36\pi$  sq m
  - K.  $48\pi$  sq m
- 

THIS IS THE END OF THE TEST. IF TIME REMAINS, YOU MAY CHECK YOUR ANSWERS TO PART 2 AND PART 1. BE SURE THAT THERE ARE NO STRAY MARKS, PARTIALLY FILLED ANSWER CIRCLES, OR INCOMPLETE ERASURES ON YOUR ANSWER SHEET. ■

▶▶▶ Scrambled Paragraphs

**Paragraph 1 (RUQST)**

The first sentence in each paragraph is called the given sentence. In this paragraph, the given sentence is a question, and R contains the answer—the song “Take Me Out to the Ballgame.” The choice of the next sentence is more difficult. At first glance, it appears to be Q, which refers to the composer and lyricist of the song. S continues the train of thought by stating when the lyricist first attended a ballgame, and T logically follows by referring to the composer, who attended a ballgame some time after the lyricist. The resulting four-sentence paragraph (RQST) is logically correct, but the remaining sentence, U, does not logically follow T, nor does the subject of U (“it”) have a referent in T. Thus, U must appear earlier in the paragraph. U says that “it” is sung during the seventh-inning stretch of a ballgame, so the pronoun must refer to a song. The only song title is in R. U must follow R to form paragraph RUQST, because that is the only order that has a logical place for U. The logical connection from R to U is not strong, but neither is it incorrect. This is an example of a paragraph that is solved by viewing it as a coherent whole, more than the connections between individual sentences.

**Paragraph 2 (TRQSU)**

According to the given sentence, the Indigenous people of Australia use a musical ritual to map pathways across their country. T follows the given sentence; it calls these rituals “songlines” and explains their purpose, to describe a traveler’s route. R follows T with a further description of the songlines; they are so detailed that a listener can identify specific geographic features. At this point, most readers will wonder how songlines work. Q offers an explanation: the singers communicate through patterns of notes and rhythms. These patterns can be understood by members of different clans (S). U must be last because the “opportunities to study songlines” refer to the research in Q and S.

**Paragraph 3 (UTRQS)**

The given sentence introduces the topic, the building of an abandoned settlement called Nan Madol. Sentence U logically follows because it refers to the “structures” of Nan Madol and comments on the size of its stone columns. U also mentions that the local people provided information to anthropologists about the construction of Nan Madol. The rest of the paragraph describes how the columns were quarried and transported to the building site. The “local people” in U connects to “the islanders” in T, which also explains how the stone columns were formed. Next, R describes how the ancestors of the local people split the columns from the surrounding rock. Q explains how the columns were transported to the site,

and S concludes the paragraph by describing the placement of the columns in their present positions.

**Paragraph 4 (SURQT)**

The given sentence introduces macaws as large, beautiful birds. S is next, referring to an additional attribute of macaws, their intelligence, and claiming that some macaw behaviors are not well understood. U is next with an example of such behavior, eating clay in river mud. Why do they eat mud? Not to satisfy their hunger, according to R. Q follows with a theory to explain the behavior: macaws ingest the clay to counteract toxins found in the fruit seeds they have eaten. T concludes the paragraph by explaining that macaws will eat more clay in the dry season, when safer food is scarce and the birds are presumably eating more poisonous fruit seeds.

**Paragraph 5 (SUTQR)**

The given sentence states what early European traders thought about Africa, setting the reader up for a contrasting statement. S fills that role, stating that European travelers to Africa began to change their impressions. The reason for their change in perception is given in U—their visits to the thriving city of Timbuktu. Among the remaining sentences, the best sentence to follow U is T. Both take place in the fifteenth century, and “these stories” in T refers to the travelers’ tales about Timbuktu in U. T also names a specific explorer, Benedetto Dei. Q begins with the pronoun “he,” referring to Dei. Only R is left, and it provides a good conclusion, both chronologically (ending with the nineteenth century) and in terms of content (the rise and fall of Timbuktu).

SUQTR might seem correct, but it contains a grammatical problem. The “he” in Q has no referent in U. (Benedetto Dei isn’t mentioned until T.) Another popular choice, SUTRQ, is incorrect because the sequence RQ does not make sense. R describes the decline of Timbuktu, while Q describes it as a thriving metropolis.

▶▶▶ Logical Reasoning

11. (B) Evaluate each option to determine the option that **must** be true. Options A, C, D, and E **might** be true, but there is not enough information given to conclude that any of them **must** be true. We cannot conclude that every student who received all A’s plays on a team (Option A), or determine whether the best athletes always get the highest grades (Option C). Option D can be ruled out because no information is given that compares grades received by students who do or do not play on sports teams. Nor is there any information about how much time students spend studying, ruling out Option E. Only Option B **must** be true. A student who receives a grade of C+, which is lower than a B-, is not permitted to play.

**12. (K)** Draw a diagram to help solve this question. Use initials to represent the names of the five students—S, R, E, A, T. Write “first” on the left side of your scrap paper and the numbers 1 through 5 after it. Then look for specific locations for each person. Statement 3 says that Tiffany used the phone last, so write “T” in the fifth position.

First                                                    
          1        2        3        4        5        T

Raymond must be in the fourth position because he used the phone after Steve (Statement 1) and after Elise and Ahmed (Statement 2).

From Statement 2, we know that Ahmed used the phone before Elise. So there are three possible orders:

SAERT        AESRT        ASERT

The first person to use the telephone could be either Steve or Ahmed, but we don’t have enough information to identify which one. Thus, Option K is the correct answer.

**13. (D)** This question requires you to order the dolls by size, from largest to smallest. Draw a diagram with a space for each doll and use the initials R, B, P, Y, and G to represent the colors.

Largest                                                    
          1        2        3        4        5

Combining the information in Statements 1, 3, and 4, the relative positions of the green, blue, red, and purple dolls (without knowing their exact locations) can be represented as:

GBRP

Now consider the location of the yellow doll. The yellow doll is **not** next to the purple doll, according to Statement 2, and is **not** between the blue and red dolls, according to Statement 1. Thus, the possible orders are:

YGBRP    GYBRP

The red doll is fourth, regardless of which order is correct. Notice that you do not have to determine the location of every doll in order to answer the question correctly.

**14. (F)** Draw a diagram to illustrate the relationship among the groups mentioned in the question: all teachers, people who went to the lecture, and people who went to the lecture and left early.

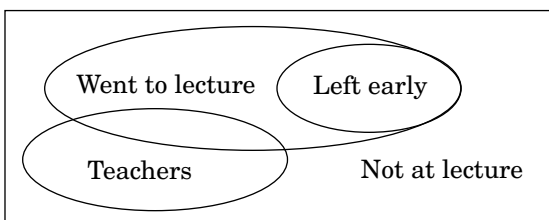

Options G, H, J, and K **might** be true, but not necessarily. Only Option F **must** be true, because none of the teachers left the lecture early.

**15. (E)** Draw a diagram to help solve this problem. Write “left” on the left-hand side of your scrap paper, followed by four spaces, one for each bike. Let an initial stand for each bike color—B, Y, G, and R. Then look for specific information about the location of a bike. The blue bike is on the extreme left (Statement 1). Fill in the left-most blank with a “B.”

Left      B                                

Based on Statement 3, there are three possible orders. (Remember that “between” does not necessarily mean “between and next to.” Another bike could also be between the blue and yellow bikes.)

BGYR    BGRY    BRGY

Based on Statement 2, we can eliminate the third possible order because the red bike must be next to the yellow bike. There are now two possible orders:

BGYR    BGRY

Paul’s bike is between the blue bike and the red bike. However, we can’t determine which of the two orders is correct, so his bike could be either green or yellow.

Options A, B, C, and D **might** be true, but we cannot conclude that they **must** be true. Only Option E **must** be true.

**16. and 17.** Read the directions carefully. The letters in a sentence may or may not appear in the same order as the words in that sentence. For example, in the first sentence, the first letter (L) may or may not represent the first word (sherbet). Remember that you need not find out what every letter represents in the code.

**16. (J)** The word “and” appears in the first, second, and third sentences of the code, but not in the fourth sentence. The letter that represents “and” must also appear in the first three sentences, but not in the fourth. The letter T (Option F) appears in all four sentences, so it cannot be correct. The letters L and M (Options G and H) each appear in only two sentences, not three, so they are also incorrect. The letter Q meets the requirements. It appears in the first three sentences but not the fourth. No other letters meet this requirement, so Option J is correct.



17. (C) The letter V appears in the second and fourth sentences. Find the word that also appears only in those two sentences. Options A and B are incorrect because the words “chili” and “spicy” appear in the second sentence, but not in the fourth. Option D, “sweet,” appears in the first and fourth sentences, but not in the second sentence, so it can be ruled out. The word “hot” is the only word that appears in both the second and fourth sentences, and it is the correct answer.

18. (H) This question contains two conditional statements. You can put the two sentences together: When Tomas is wearing a white shirt, he is also wearing a tie and black shoes. Thus, Option H must be true.

W → T → B

The first sentence only tells us what will happen *when* Tomas wears his white shirt. It says nothing about what will happen when Tomas does **not** wear his white shirt. Therefore, it is incorrect to conclude that when Tomas wears a tie he is also wearing a white shirt. Likewise, the second sentence tells us only what will happen *when* Tomas wears a tie. It doesn't tell us what will happen when Tomas does **not** wear a tie. We cannot conclude that whenever Tomas wears his black shoes he is also wearing a tie.

19. (A) This question asks you to determine which of the six houses have fenced yards and which have porches. Start with the most definite information—that three houses have porches (Statement 2), and they are not next to one another (Statement 3). This creates four possible arrangements of houses with porches:

L	M	N	P	Q	R
Yes	No	No	Yes	No	Yes
Yes	No	Yes	No	No	Yes
Yes	No	Yes	No	Yes	No
No	Yes	No	Yes	No	Yes

Statement 1 says that the two houses with fenced yards are immediately next to one another. The third and fourth arrangements above do not allow this condition, because a house with a porch cannot have a fenced yard (Statement 4). Two possibilities remain, as shown below, and we cannot determine which is correct.

House	L	M	N	P	Q	R
Porch?	Yes	No	No	Yes	No	Yes
Fenced yard?	No	Yes	Yes	No	No	No

or

House	L	M	N	P	Q	R
Porch?	Yes	No	Yes	No	No	Yes
Fenced yard?	No	No	No	Yes	Yes	No

Options B, C, D, and E are true for one of the possibilities, but not the other. None of them **must** be true for both possibilities. Option A is true for both possibilities, and it is the correct answer.

20. (H) Read each option to determine whether it **must** be true. Option F is ruled out because the question refers to only two conditions, afraid or not afraid of heights. There are no comparisons of degrees of fear. The question does not state the requirements for joining the Skydiving Club (Option G), only for maintaining one's membership. Option H is correct; some people who are afraid of heights belong to the Skydiving Club, and these people make three jumps a month. There is no support for Option J, and Option K applies to skydivers in general, not to members of the Skydiving Club.

## ▶▶▶ Reading

### ▶ Wolves

21. (E) You are asked to identify the main theme of the passage. Every paragraph discusses the reasons that wolves howl, and the best answer is Option E, “purposes of wolf howling.” Option A and B are details, not the main theme. Option C is too broad for a passage that describes only wolf behavior. Option D is not mentioned at all.

22. (G) Read each option to find the statement that is **not** supported by the passage. Option F is supported by lines 18-20, so it cannot be the correct answer. In evaluating Option G, notice that the passage gives two examples of wolves communicating outside their own pack: lines 18-20, which describe howling to mark the boundaries of a pack, and lines 37-39, which describe a lone wolf looking for other wolves to begin a new pack. These examples indicate that wolves sometimes communicate outside of their own pack, contradicting Option G, and thus making it the correct answer. Option H is clearly stated in lines 22-23, Option J is supported in lines 16-18 and 40-42, and lines 16-18 rule out Option K.



**23. (C)** The comparison of birdsong to howling is found in lines 18-21: “howling may be a way to mark the boundaries of a pack’s territory, in the same way that some birds use birdsong to warn other birds away.” Only one option (C) restates this idea. Options A, B, and E are specific to wolves, not to birds, and Option D is not mentioned at all.

**24. (F)** Option F, “to celebrate a successful hunt,” is mentioned in lines 17-18. Is it the best answer? The question asks about wolves howling in chorus, ruling out the reasons that a lone wolf might howl (Options G and J). Options H and K are not mentioned in the passage. Option F is the best answer.

**25. (A)** The question refers you to the last paragraph. Some observers have claimed that wolves fake their howling in order to fool other wolves, followed by examples: deceptions about maturity (a young wolf sounding like an older wolf) or numbers (a few wolves sounding like nearly a dozen). In other words, they deceive their enemies about their lack of protection, which is Option A, “vulnerability.” Options B, D, and E are mentioned in the passage, but not in the context of deceiving enemies. Option C is not mentioned.

**26. (K)** The possibility that wolves are capable of fooling other wolves in times of danger, to disguise their youth or small numbers, is discussed in the last paragraph. Some researchers doubted this claim, as described in lines 57-60. Their doubt is based on the fact that wolf hearing is too keen to be deceived, which is Option K. Options F and H support the claim that wolves **can** fake their howling, so they cannot be correct. Options G and J are not supported by the passage.

### ► Samizdat

**27. (D)** The correct answer must incorporate all of the important elements of the reading passage, yet it must not be overly broad. Option A mentions two important samizdat writers, but they are mentioned only in the fourth paragraph and are not the main topic. Option B refers to all poetry published in the Soviet Union, not limited to samizdat poetry, so it is too broad. Option C is incorrect because the passage is about the Soviet Union, which had neither a free press nor a free society (lines 6-9). Option D is a good summary of the passage, describing Soviet censorship and the samizdat response. Option E is mentioned only briefly in the first paragraph and does not summarize the theme of the passage.

**28. (H)** The earliest phase of samizdat is described in lines 35-36: “At first, samizdat focused mainly on literature, such as poetry and novels.” Only Option H, a short story, fits into this category. None of the other options are representative of the earliest phase of samizdat, though they might be examples of later stages.

**29. (B)** To answer this question, you must read more than the sentence containing the phrase “a knock at his door in the middle of the night” (lines 47-48). Reread the fourth paragraph. It says that Pasternak feared that he would appear disloyal to the Soviet state. What did he fear? Lines 18-19 state, “Most worried that they were being watched by the government’s secret police.” The correct answer is most likely that Pasternak feared a visit by the secret police, which is Option B. The other options are mentioned in the passage but are not objects of fear, as the secret police were.

**30. (J)** The correct answer must be in the last paragraph, the only paragraph to mention computers (lines 66-70). The passage does not specify the content of the texts stored on computers, so Options F and G can be ruled out. Nor did the computers give access to Russian stores, which eliminates Option H. Option J is the best answer, since storing and circulating texts via computers is more efficient than typing or hand-copying samizdat texts. Option K is not mentioned in the passage.

**31. (B)** Because a samizdat document was unsigned or signed with a false name (lines 33-34), the identity of the original writer or copyist was not part of the document. The answer to this question is not stated directly in the passage but can be inferred from lines 16-19. The best answer is that the unsigned documents protected samizdat writers from capture and punishment, which is Option B. Options A and E are not likely reasons—the materials were in fact smuggled outside the Soviet Union and copied over and over. Option C might look attractive, but the samizdat documents were unsigned to protect the identities of the writers, not of the secret police. Since all samizdat documents were unsigned, that was not a factor in judging their trustworthiness (Option D).

**32. (F)** The answer is found in lines 71-75. The correct answer, Option F, makes the connection between the abolishment of censorship and subsequent freedom of the press, which eliminated the need for samizdat. The passage does not support Options G or K, and it contradicts Option H. Option J is a true statement, but is not the reason that samizdat networks ended.

► Ice

**33. (C)** The structure of the passage is straightforward. It begins by asking why ice is slippery (lines 3-5) and reviews several theories of slipperiness: smoothness, friction, pressure, and Faraday’s theory. Option C, “answers to the question of what makes ice slippery,” summarizes the theme of the passage. Option A is not mentioned, and Options B, D, and E are details, not the main idea.

**34. (F)** Read the entire last paragraph. The writer says, “The phenomenon of a slippery liquid-like surface is not limited to ice,” then goes on to mention lead and diamond crystals. The most likely reason that the author mentions these crystals is to illustrate that solids other than ice have slippery surfaces, which is Option F. Option G cannot be correct because these crystals are made of lead and carbon, not water. The properties of lead and diamond crystals do not cast doubt on Faraday’s theory, ruling out Option H. While it is possible that scientists might shoot electrons at lead and diamond surfaces (Option J) or find new uses for slippery substances (Option K), these are not mentioned in the passage.

**35. (C)** Faraday’s experiment is described in the fourth paragraph, which states that the liquid on the ice cubes’ surfaces froze solid when the surfaces made contact (lines 45-46). This information is restated in the correct answer, Option C. Option A is incorrect because Faraday’s explanation does not include the concept of friction. Options B and D are not supported by the passage. While the surfaces of the ice cubes might be smooth (Option E), the “smoothness” explanation of slipperiness was ruled out in the first paragraph.

**36. (F)** The 1996 experiment at Lawrence Berkeley Laboratory is mentioned in lines 52-58. The data from this experiment suggested that the ice surface remained “liquid-like,” creating a slippery layer of molecules on the ice surface. This conclusion is best summarized by Option F. Option G is wrong because the experiment illustrated the power, not the weaknesses, of scientific technology. Option H is impossible: the experiment was conducted long after Faraday’s lifetime (150 years ago, see line 40). Option J contradicts the scientists’ conclusion, and Option K refers to Faraday’s experiment, not the Lawrence Berkeley Lab experiment.

**37. (B)** This question asks you to distinguish between “liquid-like” and “liquid.” The distinction between the two terms is made in lines 65-68: on the ice surface, “the molecules move only up and down; if they also moved side to side, they would constitute a true liquid.” Thus,

the surface of ice is liquid-like because the surface molecules move only up and down, which is Option B. Option A describes the result of the experiment, not the ice surface itself. Option C can be ruled out because “wet” and “liquid” are synonyms. Option D cannot be evaluated—we do not know from the passage whether the ice surface is slipperier than a liquid surface. Option E contradicts the passage, which says that the molecules on the ice surface are in motion.

**38. (K)** The friction theory of slipperiness is explained in the second paragraph, which concluded that the theory cannot explain why ice is slippery for someone who stands motionless, creating no friction. A phenomenon that a theory cannot explain can be said to weaken, or undermine, the theory. Option K, “a person slipping while standing immobile on ice,” is the best answer. Option F undermines the pressure theory of slipperiness, not the friction theory, while Option J undermines the “smoothness” explanation. Options G and H neither support nor undermine the friction theory.

► Great Zimbabwe

**39. (D)** You are asked to identify the general topic of the passage. Options B and E refer to only parts of the passage. Option C is not mentioned at all. Option A is too broad; most of the passage is about Great Zimbabwe, not the nation of Zimbabwe. Option D, “the true story of the Great Zimbabwe ruins,” is best.

**40. (G)** This is a synthesis question, in which the basis for the correct answer is found in several places in the passage. First, find the section that mentions Richard Hall’s opinion. Lines 52-54 state that Hall was “convinced that the structures had been built by ancient people from the Middle East.” Later, Hall’s opinion was discredited by archaeologists who demonstrated that Great Zimbabwe was African, not Middle Eastern, in origin (lines 64-65). In other words, Hall’s opinion was inaccurate. All five options must be evaluated to find the option with which the passage’s author would most likely agree. Option F is not correct: Hall’s first impression (that the structures were built by people from the Middle East) was inaccurate. The author would not agree with Option H: the present culture of the Shona people is not illustrative of their past. The author does not take any stand on whether advanced cultures developed first in the Middle East, ruling out Option J, nor does the author claim that Middle Eastern culture was derived from Shona culture (Option K). The best answer is Option G. A preconception is an opinion formed in advance of actual knowledge, which perfectly describes Hall’s belief.



Hall's preconception that Great Zimbabwe was built by people from the Middle East clouded his judgment.

**41. (E)** Read the entire last paragraph, which implies that discussion of “one mystery of Great Zimbabwe” has just been concluded, and the author is making a transition to another mystery. The previous paragraph showed that Great Zimbabwe was built by ancestors of the Shona people during the fourteenth or fifteenth century, not by ancient people from the Middle East. Thus, the mystery, now solved, was who had built Great Zimbabwe and when (Option E). Option A is a detail of the correct answer, but incorrect because the mystery comprised much more than the foreign wares discovered in the ruins. Option B, “why the settlement was abandoned,” is the remaining mystery, not the mystery that had been solved. The source of the gold and ivory (Option C) and the reason that Europeans did not discover Great Zimbabwe until the 1870s (Option D) are not presented as mysteries.

**42. (H)** The Shona people are discussed in the fifth paragraph. Since the question is open-ended, we must evaluate each option to find the best answer. The Shona people still exist as a distinct group (line 68), ruling out Option F. Shona kings traded their goods in coastal towns (lines 72-74), implying that they lived in the African interior, not the coast, eliminating Option G. (This conclusion is also supported by line 18: “a mysterious stone city in the African interior.”) Lines 65-68 state that Great Zimbabwe was most likely built by ancestors of the present-day Shona people, which supports Option H. Options J and K confuse the histories of the Shona people and ancient Middle Eastern people. Option H is the best answer.

**43. (E)** The statement “Archaeology was still in its infancy” (lines 51-52) implies that the field of archaeology was young and immature in the 1870s. The statement is followed by descriptions of how early explorers, including Richard Hall, discarded valuable archaeological material that would have revealed the true history of Great Zimbabwe. Thus, the “infancy” of archaeology is illustrated by Option E, “the excavations conducted by Richard Hall.” Options A and B are events in Shona history, not the history of archaeology, and Options C and D are references to more advanced stages of archaeology, not to its infancy.

**44. (F)** The phrase “relationship of Portuguese explorers to Great Zimbabwe” is open-ended, and thus each option should be evaluated in turn. Option F is correct; the Portuguese searched for Great Zimbabwe but never found it (lines 26-27). It is a good idea to read the remaining options to be sure that none of them is better than

Option F. Options G, H, and K are incorrect because the Portuguese never found Great Zimbabwe or King Solomon's mines. The destruction of archaeological evidence was committed by subsequent explorers, not the Portuguese, which rules out Option J. Option F is the best answer.

### ► Cross Country

**45. (E)** Options A and B are details, not the main theme. Options C and D are too broad—the passage is about one automobile journey, not travel in general. Option E, “a historic automobile trip by twentieth-century pioneers,” correctly sums up the main idea of the passage.

**46. (F)** The correct answer (Option F) is stated directly in the preceding sentence (lines 31-32): “Residents of some small towns had never seen an automobile.”

**47. (B)** Read the entire sentence to understand the context of the phrase. “The modern machine attracted so much attention that Jackson's bulldog Bud was given the responsibility of guarding the car from people who, enchanted by its novelty, were tempted to steal a shiny piece as a souvenir.” A novelty is something new or unusual. In this sentence, the novelty is the car, Option B. Option E, “journey,” might look attractive because the journey could also be considered a novelty, but “journey” does not fit the sentence—it does not have shiny pieces that people were tempted to steal.

**48. (G)** The incident with the farmer and his horses is described in lines 39-44. The car sank into quicksand and had to be pulled out by a farmer's team of horses. Options F and K are contradicted, not supported, by this incident. Option H refers to another incident. Option J might or might not be true, but the incident is about only one quicksand pit, not many. Option G is the correct inference. Despite their modern machine, Jackson and Crockett occasionally needed help from other people, such as the farmer.

**49. (C)** A cross-country automobile trip in 1910 is mentioned in lines 51-54: “By 1910, other drivers, benefitting from better driving conditions, had shortened the transcontinental crossing time to ten days.” Better driving conditions imply better highways, which is Option C.

**50. (F)** The complete phrase is “their predecessors who traveled in covered wagons” (lines 56-58). The only option that fits that description is “the early settlers” (Option F).





- 51. (A)** AB lies between 0 and 1 on the number line. A is the lower limit of  $x$  and B is the upper limit. The area between 0 and 1 is divided into 6 equal segments, so  $A = \frac{1}{6}$  and  $B = \frac{3}{6} = \frac{1}{2}$ .

- 52. (J)** Let  $x$  represent the lowest score that Hilary can receive and earn a B, which requires an average score of 80 points. Set up the equation for the calculation of a mean of 80:

$$\frac{91 + 72 + 69 + 83 + x}{5} = 80$$

$$\begin{aligned} 91 + 72 + 69 + 83 + x &= 400 \\ 315 + x &= 400 \\ x &= 85 \end{aligned}$$

- 53. (A)** When the three 14-foot chains are linked end to end, their length is  $3 \times 14 \text{ ft} = 42 \text{ ft}$ . Let  $x$  represent the length of one of the longer chains and set up an equation:

$$\begin{aligned} 42 + 2x &= 100 \\ 2x &= 58 \\ x &= 29 \end{aligned}$$

- 54. (K)** To find “how many times older,” divide the age of the earth by the age of the artifact:

$$\begin{aligned} \frac{5.2 \times 10^9}{1.3 \times 10^7} &= \frac{5.2}{1.3} \times \frac{10^9}{10^7} \\ &= 4.0 \times 10^2 \end{aligned}$$

- 55. (B)** The first step is to cross-multiply. Then, use the distributive property. Next, combine like terms and solve the equation:

$$\begin{aligned} 3(7 + n) &= 1(43 + n) \\ 21 + 3n &= 43 + n \\ 3n - n &= 43 - 21 \\ 2n &= 22 \\ n &= 11 \end{aligned}$$

- 56. (H)** To get the prime factorization, divide out prime numbers until all that is left are prime numbers. One way is shown below:

$$\begin{aligned} 1,200 &= 2 \times 600 \\ &= 2 \times 2 \times 300 \\ &= 2 \times 2 \times 2 \times 150 \\ &= 2 \times 2 \times 2 \times 2 \times 75 \\ &= 2 \times 2 \times 2 \times 2 \times 5 \times 15 \\ &= 2 \times 2 \times 2 \times 2 \times 5 \times 3 \times 5 \\ &= 2^4 \times 3 \times 5^2 \end{aligned}$$

- 57. (B)** Substitute  $y - 7$  for  $x$  and simplify the expression:

$$\begin{aligned} 3(y - 7) - 3 \\ 3y - 21 - 3 \\ 3y - 24 \end{aligned}$$

- 58. (H)** First, calculate the total distance Laura traveled:

$$\begin{aligned} (15 \text{ mph}) \times (2 \text{ hr}) &= 30 \text{ miles} \\ (12 \text{ mph}) \times (1 \text{ hr}) &= 12 \text{ miles} \end{aligned}$$

$$\begin{aligned} \text{Total distance traveled} &= 30 + 12 = 42 \text{ miles.} \\ \text{Total time traveled} &= 2 + 1 = 3 \text{ hours.} \end{aligned}$$

To calculate her average speed for the entire ride, divide total distance traveled by total time traveled:

$$42 \div 3 = 14 \text{ miles per hour}$$

- 59. (E)** Using the counting principle:

4 people can be chosen for the first position  
3 people can be chosen for the second position  
2 people can be chosen for the third position  
1 person can be chosen for the fourth position

$$\text{So, } 4 \times 3 \times 2 \times 1 = 24.$$

Another way to solve this problem is by writing out all the possible permutations (using the letters L, M, P, and R to represent the four people) and then count them:

LMPR	MLPR	PLMR	RLMP
LMRP	MLRP	PLRM	RLPM
LPMR	MPLR	PMLR	RMLP
LPRM	MPRL	PMRL	RMPL
LRMP	MRLP	PRLM	RPLM
LRPM	MRPL	PRML	RPML



60. (G) Begin by cross-multiplying to eliminate the fraction, then combine like terms and solve for  $m$ :

$$\begin{aligned} 5m - 3 &= 4(2 + m) \\ 5m - 3 &= 8 + 4m \\ m &= 11 \end{aligned}$$

61. (D) Substitute  $-3$  into the expression wherever you see an  $x$ , and then simplify:

$$\begin{aligned} 4x^2 + 5x - 8 \\ 4(-3)^2 + 5(-3) - 8 \\ 4(9) - 15 - 8 \\ 13 \end{aligned}$$

62. (K) The formula for the area ( $A$ ) of a rectangle is length ( $l$ ) times width ( $w$ ):  $A = l \cdot w$ . The question defines the length in terms of the width:  $l = 3w$ . Substituting  $3w$  for  $l$ , we get:

$$A = 3w \cdot w = 3w^2$$

Since the question states that  $w = 8$ :

$$3(8^2) = 3(64) = 192 \text{ sq ft}$$

63. (C) Since 75% is the same as  $\frac{3}{4}$ , we know the number of students in the class must be divisible by 4. The number of students in the class also needs to be divisible by 6, since exactly  $\frac{1}{6}$  of the students do not have a book bag.

The numbers between 30 and 41 that are divisible by 4 are 32, 36, and 40. Of those three numbers, only 36 is also divisible by 6. So the answer is C, 36.

64. (K) The angles are formed by the intersection of two lines. The angle labeled  $53^\circ$  is opposite to the unlabeled angle, which by definition is also  $53^\circ$ . The sum of the four angles is  $360^\circ$ . Neither  $x$  nor  $y$  is being solved for, only their sum ( $x + y$ ).

$$\begin{aligned} x + y + 2(53) &= 360 \\ x + y &= 360 - 106 \\ x + y &= 254 \end{aligned}$$

65. (D) When the sum of two integers is odd, one integer must be odd and the other must be even. The sums  $N + M$  and  $M + T$  are both odd. If  $M$  is odd, then both  $N$  and  $T$  are even. If  $M$  is even, then both  $N$  and  $T$  are odd.

Evaluate each answer option. Options A and B **may** be true, but neither **must** be true. If  $N$  and  $T$  are both even, their product will be even; if both are odd, their product will be odd. Thus, neither option **must** be true.

Regardless of whether  $N$  and  $T$  are both odd or both even, Options C and E cannot be true. In both cases,  $N - T$  and  $N + T$  would be even.

Option D will always be true, because the sum of two odd numbers is always even and the sum of two even numbers is always even.

66. (H)  $\frac{4.5}{0.1} \times 0.22 = 45 \times 0.22 = 9.9$

67. (D) Begin by evaluating the problem as it is written. Following the order of operations, we first calculate the expression in the parentheses, and then perform the division:

$$\begin{aligned} (8 - 16) \div (-8 + 6) \\ = (-8) \div (-2) \\ = 4 \end{aligned}$$

Now, remove the parentheses and evaluate the resulting expression. Following the order of operations, we first perform the division and then the addition:

$$\begin{aligned} 8 - 16 \div -8 + 6 \\ = 8 + \frac{-16}{-8} + 6 \\ = 8 + 2 + 6 \\ = 16 \end{aligned}$$

To calculate how the value of the expression changes by removing the parentheses, subtract the first answer from the second answer:

$$16 - 4 = 12$$

The expression will change by an increase of 12.



68. (F) To find the value of  $x$  in terms of  $y$ , solve for  $x$ :

$$\begin{aligned} 2x + 2y - 6 &= 14 \\ 2x + 2y &= 20 \\ x + y &= 10 \\ x &= 10 - y \end{aligned}$$

69. (D) First, calculate the number of complete trips around the merry-go-round the child will make. Then, determine how many horses remain in the final trip. 337 (the number she stops at) divided by 25 (the number of horses on the merry-go-round) equals 13, with a remainder of 12. Thus, the child will walk around the merry-go-round 13 complete times and stop at the 12<sup>th</sup> horse on her next trip. The 12<sup>th</sup> letter of the alphabet is L, so the answer is D.

70. (K) Since there are 16 ounces in 1 pound, the question asks how much we would pay for 16 ounces of this candy. Set up a proportion based on what is given in the problem:

$$\frac{5 \text{ oz}}{\$1.50} = \frac{16 \text{ oz}}{x}$$

Now, solve for  $x$ , which would be the price of 16 ounces of candy:

$$\begin{aligned} 5x &= 16(\$1.50) \\ 5x &= \$24 \\ x &= \$4.80 \end{aligned}$$

71. (B) A ratio of 3:2 means that in any group of 5 people, 3 are women and 2 are men.

Thus,  $\frac{3}{3+2}$  or  $\frac{3}{5}$  are women.  $\frac{3}{5} = \frac{6}{10} = 60\%$ .

72. (H) 75 is evenly divisible by 15, so 77 (i.e.,  $75 + 2$ ) is the first integer that has a remainder of 2 when divided by 15. Add 15 to 77 ( $= 92$ ) to get the next integer. Add 15 to 92 ( $= 107$ ) to get the next integer. However, 107 is larger than 105, so only 2 integers (77 and 92) satisfy the conditions, and the correct answer is H.

73. (B) Solve the equation:

$$\begin{aligned} \frac{2(x+1)}{3} &= 1 \\ 2x+2 &= 3 \\ x &= \frac{1}{2} \end{aligned}$$

74. (G) After the initial \$2.00 charge, the cost per mile is  $\$0.30 \times 5 = \$1.50$ . Let  $x$  equal the number of miles ridden for a \$20 fare, and set up an equation for the total cost of the taxi ride:

$$\begin{aligned} \$2.00 + \$1.50x &= \$20.00 \\ \$1.50x &= \$18.00 \\ x &= 12 \text{ miles} \end{aligned}$$

75. (B) First, calculate the location of point J using the location of point K and the given length of JK:

$$\frac{3}{8} - 3\frac{1}{2} = -3\frac{1}{8}$$

Now, use the location of point J to calculate the location of point M using the length of JM:

$$-3\frac{1}{8} + 9\frac{3}{4} = 6\frac{5}{8}$$

Finally, use the location of point M to calculate the location of point L using the length of LM:

$$6\frac{5}{8} - 1\frac{1}{8} = 5\frac{1}{2}$$

76. (G) Shelby paid 40% on the first day of the month and 25% on the tenth day. That means she owes a total of 35% on the twentieth day ( $100\% - 40\% - 25\% = 35\%$ ).

$$\$800 \times 0.35 = \$280$$

Another way to solve this problem is to calculate what Shelby paid on each day and subtract that from the total amount due:

$$\begin{aligned} \text{First day: } & \$800 \times 0.40 = \$320 \\ \text{Tenth day: } & \$800 \times 0.25 = \$200 \\ \text{Twentieth day: } & \$800 - \$320 - \$200 = \$280 \end{aligned}$$

77. (D) Substitute  $-2$  for  $x$  and  $3$  for  $y$ , and simplify the expression:

$$\begin{aligned} 5x - 2xy \\ 5(-2) - 2(-2)(3) \\ -10 - (-12) \\ -10 + 12 \\ 2 \end{aligned}$$



- 78. (F)** Because both triangles are right triangles that share a vertex, they are similar. To find  $x$ , set up a proportion using the two known sides of each triangle:

$$\frac{(4 + x)}{1.0} = \frac{4}{0.8}$$

$$0.8(4 + x) = 1.0(4)$$

$$4 + x = 5$$

$$x = 1$$

- 79. (E)** Start by setting up an equation for each comparison mentioned in the problem:

**Equation 1:**  $s = 4l$

**Equation 2:**  $2p = 5d$

**Equation 3:**  $3h = p$

**Equation 4:**  $5s = 2h$

Now, assign a value to one variable and solve for the others:

Let  $l = 1$

So, using Equation 1:  $s = 4 \cdot 1 = 4$

Then, use Equation 4:  $5 \cdot 4 = 2h$   
 $10 = h$

Then, use Equation 3:  $3 \cdot 10 = p$   
 $30 = p$

Finally, use Equation 2:  $2 \cdot 30 = 5d$   
 $12 = d$

Now that the values of all 5 coins are known, the coin with the greatest value is plunk (30).

- 80. (H)** Raoul is now  $R$  years old, and Phil is 8 years older:

$$P = R + 8$$

Two years from now, Phil will be twice as old as Raoul:

$$(P + 2) = 2(R + 2)$$

By substitution,

$$[(R + 8) + 2] = 2(R + 2)$$

$$R + 10 = 2R + 4$$

$$6 = R$$

Raoul is currently 6 years old.

- 81. (D)** First, calculate the area we need to paint:

$$\begin{aligned} &2 \text{ walls each measuring } 12 \text{ ft by } 9 \text{ ft} \\ &= 2 \times 12 \times 9 = 216 \text{ sq ft} \end{aligned}$$

$$\begin{aligned} &2 \text{ walls each measuring } 10 \text{ ft by } 9 \text{ ft} \\ &= 2 \times 10 \times 9 = 180 \text{ sq ft} \end{aligned}$$

$$\text{Total area} = 216 + 180 = 396 \text{ sq ft}$$

1 qt covers 100 sq ft, so divide the total square feet by 100 to find the number of quarts needed:

$$\frac{396}{100} = 3.96 \text{ qt}$$

Since we cannot buy a partial can of paint, we need to round up. The answer is 4 quarts.

- 82. (G)** Rearrange the equation so that  $nm$  is on one side:

$$60 = 24nm$$

$$2.5 = nm$$

- 83. (C)** Find the multiples of 7 and multiples of 5, add the remainders to each multiple, and look for the first number to appear in both lists:

Multiples of 7:	7	14	21	28	35 ...
Add 3 to each:	10	17	24	31	38 ...

Multiples of 5:	5	10	15	20	25 ...
Add 2 to each:	7	12	17	22	27 ...

17 is the first number to appear in both sequences, so it is the least possible value to meet the conditions.

An alternative way to solve this problem is to test each answer option to see which one fits the criteria.

- 84. (H)** The question states that the mean of 4 of the numbers is 50. To solve this problem, we can assume that the value of each of those 4 numbers is 50.

Now, let  $x$  equal the mean of the other 16 numbers. Set up an equation using the mean of all 20 numbers to find the value of  $x$ :

$$\frac{4(50) + 16x}{20} = 42$$

$$200 + 16x = 840$$

$$16x = 640$$

$$x = 40$$



- 85. (D)** For  $x$ , determine the perfect square that lies between 50 and 65.  $8^2 = 64$ , so  $x = 8$ . For  $y$ , find the perfect square that lies between 17 and 32.  $5^2 = 25$ , so  $y = 5$ . Then multiply  $x$  and  $y$ :

$$8 \times 5 = 40$$

To quickly solve problems like this, it is important to know the perfect squares at least through  $12^2 = 144$ .

- 86. (J)** Twenty-five percent of the sample of 2,000 homes is 500 homes. The first year in which at least 500 homes had DVRs was 2006, which is Option J.

- 87. (B)** We know that 300 dollars = 192 nobles. To figure out how many nobles are equal to 1 dollar, divide each side of the equation by 300:

$$300 \text{ dollars} \div 300 = 192 \text{ nobles} \div 300$$

$$1 \text{ dollar} = \frac{192}{300} \text{ nobles} = \frac{16}{25} \text{ nobles}$$

- 88. (G)** First, change both fractions into mixed numbers:

$$\frac{28}{3} = 9\frac{1}{3}$$

$$\frac{83}{5} = 16\frac{3}{5}$$

The positive integers between these mixed numbers are 10, 11, 12, 13, 14, 15, and 16. So the answer is 7.

- 89. (C)** We know that  $KT = 12$  units and  $M$  is the midpoint of  $\overline{KT}$ , so  $MT = 6$  units. We know that  $W$  is the midpoint of  $\overline{MT}$ , so  $WT = 3$  units.

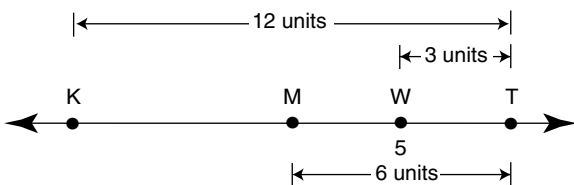

If we assume that  $K$  is smaller than  $T$ , then  $K$  must be to the left on the number line and  $T$  must be to the right. Since we know that  $W$  is at 5 on the number line,  $T$  must be at 8 because  $WT = 3$  units, and  $M$  must be at 2, since  $MW = 3$  units.

Given that  $KT = 12$ , and  $T$  is at 8 on the number line, then  $K$  must be at  $-4$ .

Finally, we need to find the midpoint of  $\overline{KW}$ :

$$\frac{-4 + 5}{2} = \frac{1}{2} = 0.5$$

Note: The question asks for “a possible midpoint” of  $\overline{KW}$  because there is no information about whether  $K$  is smaller than  $T$ , or  $T$  is smaller than  $K$ . In the explanation above, we assumed that  $K$  is smaller than  $T$ . If we assume  $T$  is smaller than  $K$ , we would get a different answer for the midpoint of  $\overline{KW}$  (9.5), which is not among the answer options.

- 90. (H)** First, calculate what  $t$  is when the two planes are equal distances from the airport. Set the two distances equal to each other and solve for  $t$ :

$$310 - 2t = 3t + 235$$

$$-5t = -75$$

$$t = 15$$

The question asks “what is the difference between their altitudes?” To answer this, we need to subtract the two altitudes:

$$(32,800 - 20t) - (31,600 + 40t)$$

$$= 32,800 - 20t - 31,600 - 40t$$

$$= 1,200 - 60t$$

Now, substitute the value of  $t$  into the expression:

$$= 1,200 - 60(15)$$

$$= 1,200 - 900$$

$$= 300 \text{ ft}$$

- 91. (C)** Since  $A_k = \frac{1}{k}$ , then  $A_1 = \frac{1}{1}$ ,  $A_2 = \frac{1}{2}$ , and so on.

$$A_1A_2 + A_2A_3 + A_3A_4 + A_4A_5 + A_5A_6$$

$$= \frac{1}{1} \times \frac{1}{2} + \frac{1}{2} \times \frac{1}{3} + \frac{1}{3} \times \frac{1}{4} + \frac{1}{4} \times \frac{1}{5} + \frac{1}{5} \times \frac{1}{6}$$

$$= \frac{1}{2} + \frac{1}{6} + \frac{1}{12} + \frac{1}{20} + \frac{1}{30}$$

$$= \frac{30 + 10 + 5 + 3 + 2}{60}$$

$$= \frac{50}{60}$$

$$= \frac{5}{6}$$



- 92. (G)** There are two extreme values for the number of drivers who both wear glasses and are over age 30. (There are many more values between the extremes, but this explanation focuses on the largest and smallest.)

**Value 1:** If the 10,000 who do **not** wear glasses (50,000 – 40,000) are all 30 years old or less, that means that all 30,000 of the drivers over 30 must wear glasses.

**Value 2:** If the 10,000 who do **not** wear glasses are all over 30, that means that 20,000 of the drivers over 30 (30,000 – 10,000) must wear glasses.

Of those two values, 20,000 is smaller than 30,000, so the answer is 20,000.

- 93. (B)** First, find the new volume ( $V_2$ ) associated with the changes described in the question (dividing  $r$  by 2 and doubling  $h$ ):

$$V_2 = \frac{1}{3} \pi \left(\frac{r}{2}\right)^2 (2h) = \frac{1}{3} \pi \left(\frac{r^2}{4}\right)(2h) = \frac{1}{6} \pi r^2 h$$

Now, calculate the ratio between  $V_2$  and the original  $V$ :

$$V_2 : V$$

$$\frac{1}{6} \pi r^2 h : \frac{1}{3} \pi r^2 h$$

Cancel out the like terms:

$$\frac{1}{6} : \frac{1}{3}$$

Finally, multiply both sides by 6 to get rid of the fractions:

$$1:2$$

- 94. (G)** Evaluate each option to determine which expression **must** be positive. Options F and H must be negative, and Options J and K could be either positive or negative. Only Option G **must** be positive, because the addition of a positive number ( $z$ ) and the square of any number ( $w^2$ ) will always be positive.

An alternate way to solve this problem is to assign values to each variable (e.g.,  $w = -1$  and  $z = 1$ ), and test each answer option.

- 95. (D)** The integer values of  $x$  we need to consider are 0, 1, 2, 3, 4, and 5. Plug each of these values into the expression to see whether the result is an integer:

$$x = 0 \quad \frac{2x + 5}{x - 2} = \frac{-5}{-2}, \text{ which is not an integer.}$$

$$x = 1 \quad \frac{2x + 5}{x - 2} = \frac{-7}{-1} = 7, \text{ which is an integer.}$$

$$x = 2 \quad \frac{2x + 5}{x - 2} = \frac{9}{0}, \text{ which is not an integer.}$$

$$x = 3 \quad \frac{2x + 5}{x - 2} = \frac{11}{1} = 11, \text{ which is an integer.}$$

$$x = 4 \quad \frac{2x + 5}{x - 2} = \frac{13}{2}, \text{ which is not an integer.}$$

$$x = 5 \quad \frac{2x + 5}{x - 2} = \frac{15}{3} = 5, \text{ which is an integer.}$$

Thus, there are 3 integer values of  $x$  (1, 3, and 5) that make the expression an integer.

- 96. (K)** First, calculate the midpoint of the first line segment whose points are given:

$$\text{Midpoint of } x\text{-value: } \frac{6 + 12}{2} = \frac{18}{2} = 9$$

$$\text{Midpoint of } y\text{-value: } \frac{8 + 10}{2} = \frac{18}{2} = 9$$

So, the midpoint of the first line segment is (9, 9).

Now, use that information to find  $x$ . Set up the midpoint formula for the  $x$ -value of the second line segment using the two given points:

$$\frac{8 + x}{2} = 9$$

$$8 + x = 18$$

$$x = 10$$

- 97. (C)** We know that  $p$  is a positive even integer less than 11, so the options for  $p$  are 2, 4, 6, 8, or 10. The options for  $p^2$  are then 4, 16, 36, 64, or 100.

You could check the GCF for each pair ( $p^2$ , 81), but there is a quicker way to solve this.

We know that  $81 = 3 \times 3 \times 3 \times 3$ ; therefore, the correct  $p^2$  option must be divisible by 3. Only  $p^2 = 36$  is divisible by 3, so  $p = 6$  must be the solution.

- 98. (G)** The formula to calculate the measure of an interior angle of a polygon is  $\frac{180(n-2)}{n}$ , where  $n$  = the number of sides of the polygon. To solve this problem, substitute  $n = 12$  (the number of sides given):

$$\frac{180(12-2)}{12} = \frac{180(10)}{12} = 150^\circ$$

- 99. (D)** Use the mean of  $w, x, y,$  and  $z$  to solve for  $w$ :

$$\frac{w+x+y+z}{4} = 60$$

$$w+x+y+z = 240$$

$$w = 240 - x - y - z$$

Similarly, use the mean of  $v, x, y,$  and  $z$  to solve for  $v$ :

$$\frac{v+x+y+z}{4} = 62$$

$$v+x+y+z = 248$$

$$v = 248 - x - y - z$$

Now, you can solve  $v - w$ :

$$\begin{aligned} v - w &= (248 - x - y - z) - (240 - x - y - z) \\ &= 248 - 240 \\ &= 8 \end{aligned}$$

- 100. (H)** It may be helpful to draw a diagram of the shed and the grazing area.

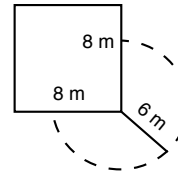

(Notice that the lengths of the sides of the shed are not important to the solution of the problem, except to prevent the goat from walking around a corner.) The resulting grazing area is a circle with radius 6 meters, minus the area of the circle taken by the shed. The shed is square so all of its corners are right angles. Thus the grazing area is  $\frac{3}{4}$  of the area of the circle. The area of a circle is  $\pi r^2$ .

$$\begin{aligned} \text{Grazing area} &= \frac{3}{4} \pi 6^2 \\ &= \frac{3}{4} \pi (36) \\ &= 27\pi \text{ sq m} \end{aligned}$$

### Answer Key for Sample Form A

Paragraph 1 R U Q S T	11. B	21. E	31. B	41. E	51. A	61. D	71. B	81. D	91. C
Paragraph 2 T R Q S U	12. K	22. G	32. F	42. H	52. J	62. K	72. H	82. G	92. G
Paragraph 3 U T R Q S	13. D	23. C	33. C	43. E	53. A	63. C	73. B	83. C	93. B
Paragraph 4 S U R Q T	14. F	24. F	34. F	44. F	54. K	64. K	74. G	84. H	94. G
Paragraph 5 S U T Q R	15. E	25. A	35. C	45. E	55. B	65. D	75. B	85. D	95. D
	16. J	26. K	36. F	46. F	56. H	66. H	76. G	86. J	96. K
	17. C	27. D	37. B	47. B	57. B	67. D	77. D	87. B	97. C
	18. H	28. H	38. K	48. G	58. H	68. F	78. F	88. G	98. G
	19. A	29. B	39. D	49. C	59. E	69. D	79. E	89. C	99. D
	20. H	30. J	40. G	50. F	60. G	70. K	80. H	90. H	100. H



Student's First Name (please print) \_\_\_\_\_

Student's Last Name (please print) \_\_\_\_\_

Student's Home Address      Apartment      Borough      ZIP Code      Home Telephone Number

**PART 1 VERBAL**

**SCRAMBLED PARAGRAPHS**

**Paragraph 1**

- The second sentence is    Q    R    S    T    U
- The third sentence is    Q    R    S    T    U
- The fourth sentence is    Q    R    S    T    U
- The fifth sentence is    Q    R    S    T    U
- The sixth sentence is    Q    R    S    T    U

**Paragraph 2**

- The second sentence is    Q    R    S    T    U
- The third sentence is    Q    R    S    T    U
- The fourth sentence is    Q    R    S    T    U
- The fifth sentence is    Q    R    S    T    U
- The sixth sentence is    Q    R    S    T    U

**Paragraph 3**

- The second sentence is    Q    R    S    T    U
- The third sentence is    Q    R    S    T    U
- The fourth sentence is    Q    R    S    T    U
- The fifth sentence is    Q    R    S    T    U
- The sixth sentence is    Q    R    S    T    U

**Paragraph 4**

- The second sentence is    Q    R    S    T    U
- The third sentence is    Q    R    S    T    U
- The fourth sentence is    Q    R    S    T    U
- The fifth sentence is    Q    R    S    T    U
- The sixth sentence is    Q    R    S    T    U

**Paragraph 5**

- The second sentence is    Q    R    S    T    U
- The third sentence is    Q    R    S    T    U
- The fourth sentence is    Q    R    S    T    U
- The fifth sentence is    Q    R    S    T    U
- The sixth sentence is    Q    R    S    T    U

**LOGICAL REASONING**

- |                        |                        |
|------------------------|------------------------|
| 11 (A) (B) (C) (D) (E) | 33 (A) (B) (C) (D) (E) |
| 12 (F) (G) (H) (J) (K) | 34 (F) (G) (H) (J) (K) |
| 13 (A) (B) (C) (D) (E) | 35 (A) (B) (C) (D) (E) |
| 14 (F) (G) (H) (J) (K) | 36 (F) (G) (H) (J) (K) |
| 15 (A) (B) (C) (D) (E) | 37 (A) (B) (C) (D) (E) |
|                        | 38 (F) (G) (H) (J) (K) |
| 16 (F) (G) (H) (J) (K) |                        |
| 17 (A) (B) (C) (D) (E) | 39 (A) (B) (C) (D) (E) |
| 18 (F) (G) (H) (J) (K) | 40 (F) (G) (H) (J) (K) |
| 19 (A) (B) (C) (D) (E) | 41 (A) (B) (C) (D) (E) |
| 20 (F) (G) (H) (J) (K) | 42 (F) (G) (H) (J) (K) |
|                        | 43 (A) (B) (C) (D) (E) |
|                        | 44 (F) (G) (H) (J) (K) |

**READING**

- |                        |                        |
|------------------------|------------------------|
| 21 (A) (B) (C) (D) (E) | 45 (A) (B) (C) (D) (E) |
| 22 (F) (G) (H) (J) (K) | 46 (F) (G) (H) (J) (K) |
| 23 (A) (B) (C) (D) (E) | 47 (A) (B) (C) (D) (E) |
| 24 (F) (G) (H) (J) (K) | 48 (F) (G) (H) (J) (K) |
| 25 (A) (B) (C) (D) (E) | 49 (A) (B) (C) (D) (E) |
| 26 (F) (G) (H) (J) (K) | 50 (F) (G) (H) (J) (K) |
| 27 (A) (B) (C) (D) (E) |                        |
| 28 (F) (G) (H) (J) (K) |                        |
| 29 (A) (B) (C) (D) (E) |                        |
| 30 (F) (G) (H) (J) (K) |                        |
| 31 (A) (B) (C) (D) (E) |                        |
| 32 (F) (G) (H) (J) (K) |                        |

**PART 2 MATHEMATICS**

**MATHEMATICS PROBLEMS**

- |                        |                        |                        |                         |
|------------------------|------------------------|------------------------|-------------------------|
| 51 (A) (B) (C) (D) (E) | 66 (F) (G) (H) (J) (K) | 81 (A) (B) (C) (D) (E) | 96 (F) (G) (H) (J) (K)  |
| 52 (F) (G) (H) (J) (K) | 67 (A) (B) (C) (D) (E) | 82 (F) (G) (H) (J) (K) | 97 (A) (B) (C) (D) (E)  |
| 53 (A) (B) (C) (D) (E) | 68 (F) (G) (H) (J) (K) | 83 (A) (B) (C) (D) (E) | 98 (F) (G) (H) (J) (K)  |
| 54 (F) (G) (H) (J) (K) | 69 (A) (B) (C) (D) (E) | 84 (F) (G) (H) (J) (K) | 99 (A) (B) (C) (D) (E)  |
| 55 (A) (B) (C) (D) (E) | 70 (F) (G) (H) (J) (K) | 85 (A) (B) (C) (D) (E) | 100 (F) (G) (H) (J) (K) |
| 56 (F) (G) (H) (J) (K) | 71 (A) (B) (C) (D) (E) | 86 (F) (G) (H) (J) (K) |                         |
| 57 (A) (B) (C) (D) (E) | 72 (F) (G) (H) (J) (K) | 87 (A) (B) (C) (D) (E) |                         |
| 58 (F) (G) (H) (J) (K) | 73 (A) (B) (C) (D) (E) | 88 (F) (G) (H) (J) (K) |                         |
| 59 (A) (B) (C) (D) (E) | 74 (F) (G) (H) (J) (K) | 89 (A) (B) (C) (D) (E) |                         |
| 60 (F) (G) (H) (J) (K) | 75 (A) (B) (C) (D) (E) | 90 (F) (G) (H) (J) (K) |                         |
| 61 (A) (B) (C) (D) (E) | 76 (F) (G) (H) (J) (K) | 91 (A) (B) (C) (D) (E) |                         |
| 62 (F) (G) (H) (J) (K) | 77 (A) (B) (C) (D) (E) | 92 (F) (G) (H) (J) (K) |                         |
| 63 (A) (B) (C) (D) (E) | 78 (F) (G) (H) (J) (K) | 93 (A) (B) (C) (D) (E) |                         |
| 64 (F) (G) (H) (J) (K) | 79 (A) (B) (C) (D) (E) | 94 (F) (G) (H) (J) (K) |                         |
| 65 (A) (B) (C) (D) (E) | 80 (F) (G) (H) (J) (K) | 95 (A) (B) (C) (D) (E) |                         |

# SAMPLE TEST, FORM B

## PART 1 — VERBAL

*Suggested Time — 75 Minutes*

45 QUESTIONS

---

### SCRAMBLED PARAGRAPHS

PARAGRAPHS 1-5

**DIRECTIONS:** In this section, arrange each group of sentences to create the best paragraph. The first sentence for each paragraph is given; the remaining five sentences are listed in random order. Choose the order for these five sentences that will create the **best** paragraph, one that is well-organized, logical, and grammatically correct. Each correctly ordered paragraph is worth **double** the value of a question in any other section of the test. No credit will be given for responses that are only partially correct.

To keep track of your sentence order, use the blanks to the left of the sentences. For example, write “2” next to the sentence you think follows the first sentence, write “3” next to the sentence you think follows “2,” and so on. You may change these numbers if you decide on a different order. When you are satisfied with your sentence order, mark your choices on your answer sheet.

---

#### Paragraph 1

The Codex Mendoza is a fascinating document describing the culture and traditions of the Aztec Indians before the Spanish conquest.

- \_\_\_\_\_ **Q.** A boy was often named for the date of his birth or for an animal or ancestor, or even for some event at the time of his birth.
- \_\_\_\_\_ **R.** The parents would also place in the child’s hands the implements that he or she would use in adult life, gently guiding them in the motions of use.
- \_\_\_\_\_ **S.** Instruments used to weave and spin were given to the girls, while tools and weapons were given to the boys.
- \_\_\_\_\_ **T.** One tradition it describes is the feast hosted by the parents of a newborn child to give that child a name.
- \_\_\_\_\_ **U.** Girls’ names, on the other hand, were frequently created to include the Aztec word for flower, *xóchitl*.

CONTINUE ON TO THE NEXT PAGE ►

---

## Paragraph 2

Stephen Crane was 24 years old when his classic Civil War novel *The Red Badge of Courage* was published in 1895.

- \_\_\_\_\_ **Q.** Unfortunately, his first novel, *Maggie: A Girl of the Streets*, which chronicled life among the poor in New York City’s Bowery slums, was not as successful.
- \_\_\_\_\_ **R.** That novel, his second, brought him almost overnight international celebrity status.
- \_\_\_\_\_ **S.** One story says that, in an attempt to recoup his losses, Crane paid people to ride the Manhattan El train carrying copies of the book.
- \_\_\_\_\_ **T.** *Maggie* was self-published by Crane when he was only 21, using money borrowed from his brother.
- \_\_\_\_\_ **U.** The loan became a loss—the gritty social realism of *Maggie* earned Crane praise from critics, but he probably gave away more copies than he sold.

---

## Paragraph 3

It might be assumed that a nature preserve would be located in a pristine wilderness, far from the noise and pollution of the city.

- \_\_\_\_\_ **Q.** A pair of bird watchers had followed one of them heading toward the island and found a thriving colony with nearly 100 nests.
- \_\_\_\_\_ **R.** During World War I, the 45-acre island was home to a petroleum refinery and two shipbuilding companies, but later Shooter’s Island became a dumping ground.
- \_\_\_\_\_ **S.** But Shooter’s Island, a nature preserve just north of Staten Island, is an exception to the rule.
- \_\_\_\_\_ **T.** Nowadays, although there is no public access to the bird colonies on Shooter’s Island, its winged inhabitants daily bring enjoyment to city dwellers who see them “commuting” into city parks.
- \_\_\_\_\_ **U.** In 1974, however, it was discovered that the abandoned dry docks there had become home to many water birds.

CONTINUE ON TO THE NEXT PAGE ►

---

**Paragraph 4**

Ancient people of the Mediterranean thought that volcanoes were caused by Vulcan, the Roman blacksmith god.

- \_\_\_\_\_ **Q.** In the same park, Mauna Loa, at 28,000 feet above the ocean’s floor, is the largest active volcano in the world.
- \_\_\_\_\_ **R.** There are dozens of active and potentially active volcanoes within the United States, including Kilauea, the most active volcano in the world.
- \_\_\_\_\_ **S.** Both of these are shield volcanoes, which means that they were formed as lava flowed in all directions from a central vent to form low, gently sloping mountains.
- \_\_\_\_\_ **T.** Volcanoes, which were named for Vulcan, are vents in the crust of the earth from which molten lava and ash erupt.
- \_\_\_\_\_ **U.** That volcano, located in Hawaii Volcanoes National Park, has been spewing lava since 1983.

---

**Paragraph 5**

A Canadian astronomer, Dr. Philip Stooke, is known for his detailed maps of the earth’s moon.

- \_\_\_\_\_ **Q.** Certain that people must have observed and drawn images of the moon before that date, Stooke examined old manuscripts, history books, and records of archaeological excavations.
- \_\_\_\_\_ **R.** When a drawing of the tomb carving was placed over a picture of the full moon, the markings lined up.
- \_\_\_\_\_ **S.** He found a photograph of a carving of dots and lines from a prehistoric tomb in County Meath, Ireland, estimated to be 5,000 years old.
- \_\_\_\_\_ **T.** “It is without doubt a map of the moon, the most ancient one ever found,” Stooke concluded.
- \_\_\_\_\_ **U.** He had long been puzzled by the lack of moon maps older than the one created in 1505 by Leonardo da Vinci.

CONTINUE ON TO THE NEXT PAGE ►

---

# LOGICAL REASONING

## QUESTIONS 11-20

**DIRECTIONS:** Read the information given and choose the **best** answer to each question. Base your answer **only on the information given**.

In a logical reasoning test, certain words must be read with caution. For example, “The red house is **between** the yellow and blue houses” does not necessarily mean “The red house is **between and next to** the yellow and blue houses”; one or more other houses may separate the red house from the yellow house or from the blue house. This precaution also applies to words such as **above, below, before, after, ahead of, and behind**.

---

11. A star named Quil is the center of four orbiting planets, which are named Dorb, Needer, Sly, and Tyne. Each planet travels in a separate orbit, and each orbit is a circle. All four orbits lie in one plane. The farther a planet is from Quil, the faster it travels.
- 1) Planet Needer is closest to Quil.
  - 2) The orbit of planet Dorb is next to the orbit of Sly.
  - 3) The orbit of Sly is farthest from the orbit of Needer.

Which planet travels fastest?

- A. Needer
- B. Dorb
- C. Sly
- D. Tyne
- E. Cannot be determined from the information given.

12. Sidney was in a contest with Alice, Huang, and Mariah to see whose airplane could fly highest.
- 1) Alice’s airplane flew higher than Huang’s airplane.
  - 2) Mariah’s airplane did not fly as high as Alice’s airplane.

Based only on the information above, which of the following is a valid conclusion?

- F. Alice won the contest.
  - G. Sidney’s airplane flew higher than Mariah’s.
  - H. Mariah’s airplane flew higher than Huang’s.
  - J. If Sidney finished second, Alice won.
  - K. If Sidney finished second, Huang finished third.
- 

13. In high school and college, Sequina played volleyball for 2 years, soccer for 3 years, and basketball for 2 years. She never played more than 2 sports during the same year.

What is the **least** number of years Sequina could have played high school and college sports?

- A. 2
- B. 3
- C. 4
- D. 5
- E. 6

CONTINUE ON TO THE NEXT PAGE ►



---

14. There are four towns in Jefferson County: Elmont, Richland, Lendle, and Mopley. Highway 14 is closed from Elmont to Richland because of flooding.

- 1) Lendle is between Elmont and Richland on Highway 14.
- 2) Mopley can be reached from Lendle, without going through Elmont or Richland.

Which of the following statements is a valid conclusion from the statements above?

- F. Mopley is not flooded.
  - G. Either Elmont or Richland is flooded.
  - H. Both Elmont and Richland are flooded.
  - J. No one can drive to Lendle on Highway 14.
  - K. Mopley cannot be reached directly from Elmont.
- 

15. One prize was awarded each week in a three-week contest. The prizes were a trip to Disney World, a big-screen television, and a computer.

- 1) Luis, Michael, and Nadia each won a prize.
- 2) Michael did not win the computer.

Which of the following pieces of additional information makes it possible to determine who won each prize?

- A. Michael won the free trip.
  - B. Luis won the television.
  - C. Luis won the computer.
  - D. Nadia won the computer.
  - E. Michael won the television.
- 

16. In the town of Hoxie, the millworkers are all over six feet tall. Every Hoxie millworker is good at math.

Based only on the information above, which of the following **must** be true?

- F. At least some people in Hoxie who are over six feet tall are good at math.
- G. At least some people in Hoxie who are good at math are not millworkers.
- H. Anyone in Hoxie who is over six feet tall works at the mill.
- J. Anyone in Hoxie who is good at math is over six feet tall.
- K. Anyone in Hoxie who is good at math works at the mill.

---

Questions 17 and 18 refer to the following information.

In the code below, (1) each letter always represents the same word, (2) each word is represented by only one letter, and (3) in any given sentence, the position of a letter is **never** the same as that of the word it represents.

L      W      Q      P      R      means  
"Marie eats pizza and chocolate."

U      Z      R      V      N      means  
"Sean likes wings and soda."

L      V      P      T      R      means  
"Jackson eats wings and pizza."

N      Y      R      X      W      means  
"Irena likes chocolate and juice."

17. Which letter represents the word "juice"?

- A. N
- B. Y
- C. X
- D. W
- E. Cannot be determined from the information given.

18. Which word is represented by the letter U?

- F. Sean
- G. likes
- H. wings
- J. and
- K. soda

CONTINUE ON TO THE NEXT PAGE ►

---

**19.** If a snobble is heavy and slow, then it is silver.

Based only on the information above, which of the following is a valid conclusion?

- A.** All snobbles are silver.
  - B.** All snobbles are heavy and slow.
  - C.** All slow snobbles are silver.
  - D.** No silver snobble is both heavy and fast.
  - E.** No gold snobble is both heavy and slow.
- 

**20.** In a cartoon, four trolls stood in a line. Their names were Banto, Gretchen, Snowflake, and Holly. One had green eyes, another had purple ears, another had red teeth, and another had white hair.

- 1) The troll with red teeth was directly in front of Snowflake, who had white hair.
- 2) Banto, who did not have green eyes, was behind Gretchen.
- 3) Gretchen had purple ears.
- 4) Snowflake was behind Holly.

If the troll with green eyes stood behind Gretchen, then what was Gretchen's position?

- F.** first
- G.** second
- H.** third
- J.** fourth
- K.** Cannot be determined from the information given.

CONTINUE ON TO THE NEXT PAGE ►

# READING

## QUESTIONS 21-50

**DIRECTIONS:** Read each passage below and answer the questions following it. Base your answers **only on information contained in the passage**. You may reread a passage if you need to. Mark the **best** answer for each question.

The beaver, the state animal of New York, has long played a role in the history of the state. Before European colonists arrived, Native Americans hunted this large rodent for fur pelts and meat. The colonists nearly exterminated beavers through overtrapping and destruction of forest habitat. During the twentieth century, however, careful management increased the beaver population of upstate New York from only about a dozen in 1895 to tens of thousands a century later.

This remarkable comeback has had significant effects on the environment. Most people know that beavers build dams, but few realize that these industrious rodents actually shape the character of the streams and forests in which they live. An average adult beaver cuts down more than a ton of wood per year. Beavers cut down only mature trees, and several beavers at work can soon open up the forest area around a pond to sunlight.

Once a dam is built across a stream, the water behind the dam forms a pond, which is warmer and more slow-moving than the stream it replaced. The pond tends to retain sediments and organic material, causing a shift in its mix of nutrients. In response, the plant and insect species that live in the pond change as well. These changes provide more food and habitat for fish and birds, which in turn attract larger animals. Thus, the beaver helps to determine the plant and animal population of its neighborhood.

As the beavers selectively cut deciduous trees such as aspen and birch from the stream banks, conifers such as spruce gradually take over the area. Eventually, when the area no longer has trees desirable for food or building supplies, the beaver colony moves on. However, the effects of beavers on their environment are noticeable to the knowledgeable observer long after the beavers have left. Their dams eventually fall apart, and the beds of their former ponds, rich in nutrients, may become farmland, grassy meadows, or lush new forests. New streambeds may develop in these former pond areas, and the meadows and farmlands that occupied them may begin to erode, continuing the cycle of stream–beaver pond–meadow–stream.

In Wyoming, wildlife scientists at the Bureau of Land Management have captured beavers and moved them to rapidly flowing streams in an attempt to halt soil erosion. The reported success of this effort suggests that beavers can be valuable allies in protecting natural resources for future generations.

21. Which of the following best tells what this passage is about?
- A. Beavers have a significant effect on the environment.
  - B. Beaver activity encourages wildlife in New York forests.
  - C. Beavers can help prevent soil erosion.
  - D. Beavers are large, industrious rodents.
  - E. Beavers have long been important to farmers.

- 22.** The changes in insect and plant life in a beaver pond result from changes in the
- F.** size of the trees used to build dams.
  - G.** temperature and flow of water in the pond.
  - H.** kinds of larger animals attracted to the area.
  - J.** number of beavers living in the pond.
  - K.** grassy meadows created by the abandoned dam.
- 23.** What is the purpose of the beaver trapping that was carried on in Wyoming?
- A.** to save beavers from becoming extinct
  - B.** to stop beavers from eroding stream banks
  - C.** to allow new forests to develop
  - D.** to study their industrious habits
  - E.** to encourage beavers to build dams in certain streams
- 24.** Near a recently abandoned beaver pond, which of the following would most likely be seen?
- F.** the effects of years of severe erosion
  - G.** untouched stands of evergreen trees
  - H.** mature birch and other deciduous trees
  - J.** dark, dimly lit forest land
  - K.** a new beaver dam being built
- 25.** The term “remarkable comeback” (line 13) refers to
- A.** the ways in which beaver dams change their environment.
  - B.** the changes that occur after a beaver colony has left an area.
  - C.** the choice of the beaver as the state animal of New York.
  - D.** the industrious work habits of the beaver.
  - E.** the increase in the beaver population during the twentieth century.
- 26.** What is the most likely reason that the author mentioned the amount of wood that a beaver can cut down in a year?
- F.** to explain how pond areas become forest land
  - G.** to suggest why beavers selectively cut down deciduous trees
  - H.** to emphasize that beavers have a major effect on their environment
  - J.** to argue that only large beaver colonies can change the environment
  - K.** to contrast beavers with other animals in their impact on the environment

CONTINUE ON TO THE NEXT PAGE ►

For centuries, a stone-faced old man looked across the White Mountains of northern New Hampshire. The Old Man of the Mountain was not a person, but rather a distinctive natural rock formation. From most viewpoints, it looked like a random heap of stones. Seen from the north, however, it resembled the profile of a stern, elderly man looking east. Until its collapse in 2003, it was one of the most photographed sights in New England.

According to geologists, the Old Man was formed during the last Ice Age some 10,000 years ago. Perched near the top of Cannon Mountain, 365 meters above Profile Lake, the face was about 12 meters tall and 8 meters across. When European-Americans settled in the area in the early 1600s, they heard Native American legends of a mountain with a great stone face. In 1805, two surveyors were the first European-Americans known to have seen the Old Man.

In 1905, a local climber discovered that the face's forehead had begun to slip from the cliffside. The slide was stopped when turnbuckles were installed. This system of screws and cables pulled the cracks tightly together, stabilizing the rock formation. Over the years, more turnbuckles were added to close other cracks. The Old Man received several "face-lifts" as well, using glue, wire, and fiberglass.

The Old Man's profile became the symbol of New Hampshire, which is known as the "Granite State." Its people have always taken pride in their state's rocky geography and their own strength and independence. Images of the Old Man appeared on license plates, the shoulder patches on police uniforms, and the New Hampshire quarter issued in 2000.

During the 1970s, an engineering company determined that the Old Man consisted of five granite layers, balanced atop one another. Behind the lowest slab, the Old Man's "chin," was a cave, hidden from view.

Only about two feet of the chin was anchored to the cliff. Surprisingly, the Old Man had balanced on its chin for many years.

During the night of May 3, 2003, the Old Man slid from its rocky perch into the valley below, the result of centuries of weathering and temperature extremes. The harsh New Hampshire winters had driven rain and snow into cracks in the granite. Water that freezes in a crack will expand, enlarging the crack and eventually splitting the rock. All that remained was a nondescript rocky slope and a few broken turnbuckles. The collapse prompted an outpouring of articles, poems, and statements from people all over the country. Some laid flowers at the viewpoint on Profile Lake, as though for a funeral.

After the collapse, a task force began working to memorialize the Old Man. It received thousands of suggestions, including construction of a plastic replica of the face on the mountainside. While that particular idea was not implemented, a museum was built at the base of Cannon Mountain, and plans have been made for a memorial. All over the state, schoolchildren still study the history and symbolism of the Old Man. He may be gone, but he is not forgotten.

27. Which of the following best tells what this passage is about?
- A. how the Old Man of the Mountain was formed
  - B. the history of the state of New Hampshire
  - C. attempts to halt the deterioration of the Old Man of the Mountain
  - D. the future of the Old Man of the Mountain
  - E. the history and significance of the Old Man of the Mountain

CONTINUE ON TO THE NEXT PAGE ►

- 28.** What is the most likely reason that European-Americans did not see the Old Man until 1805?
- F.** They did not live in the area until then.
  - G.** They had not yet stood at the correct viewpoint.
  - H.** The Old Man did not exist before that time.
  - J.** The turnbuckles had not yet been installed.
  - K.** Native Americans had invented the story.
- 29.** What caused the collapse of the Old Man?
- A.** the weight of ice and snow
  - B.** the incorrect installation of the turnbuckles
  - C.** water freezing and thawing in the cracks over centuries
  - D.** too many tourists hiking on the formation
  - E.** the slippage of the “forehead” from the cliffside
- 30.** What is the most likely reason that the writer mentioned the cave behind one of the five granite layers?
- F.** to suggest that the formation was not as stable as it appeared
  - G.** to demonstrate how ice enlarges cracks in rocks
  - H.** to explain why the turnbuckles were installed
  - J.** to account for the formation’s endurance for over 10,000 years
  - K.** to explain how the profile was formed
- 31.** The passage suggests that the Old Man was a fitting symbol for the state of New Hampshire because it
- A.** illustrated the ruggedness of the land and people.
  - B.** resembled many residents of New Hampshire.
  - C.** was created by the first residents of New Hampshire.
  - D.** was well-balanced for many years.
  - E.** suggested that the people of New Hampshire were not as sturdy as they appeared.
- 32.** Which of the following best describes the appearance of the top of Cannon Mountain today?
- F.** A few features of the Old Man remain when seen from a particular angle.
  - G.** The site looks as it did during the last Ice Age.
  - H.** A museum is on the site where the Old Man once was.
  - J.** Only random-looking rock formations remain.
  - K.** A replica of the Old Man is being built on the site.

CONTINUE ON TO THE NEXT PAGE ►

If Han van Meegeren had kept to his career as an artist, he would have been forgotten years ago. In his native Holland, he was considered a mediocre painter and the critics' reviews of his work were uncomplimentary. Angered by their rejection, van Meegeren set out in the 1920s to fool these critics into accepting his work as the work of one of the great master painters. The hoax was carefully planned. Van Meegeren decided to create a series of religious paintings, then claim to have "discovered" the lost paintings of Jan Vermeer, the great seventeenth-century Dutch painter.

Other forgers have succeeded in their deception by borrowing elements of style and imagery from several similar works by a painter. Instead of copying any one particular painting, they combine slightly altered details from these related works, such as a pose, face, or piece of furniture, to create a new work. Van Meegeren outdid these forgers. He created not just one, but an entire series of paintings that mimicked Vermeer's style without duplicating specific details. He also collected works by little-known seventeenth-century painters and stripped the paint from these paintings so that he could use the canvas. When working on his forgeries, he applied paints made in the old ways from old materials. He also used clever techniques to lend the works authenticity. For example, he gave his paintings an aged appearance by exposing them to heat until the surface cracked in the manner of old oil paint.

Next, van Meegeren pretended to have discovered and purchased these "Vermeer" paintings. The art world rejoiced and Vermeer scholars accepted the works without question. Van Meegeren became a wealthy man, selling the pictures to museums and private collectors. He felt that he had been avenged in his bitter quarrels with art critics. It almost worked.

In the end, however, van Meegeren was forced to unmask his own forgeries. Shortly

before World War II, one of the fake Vermeers had been sold to Hermann Göring, a high-ranking German official. Van Meegeren was arrested after the war as a Nazi collaborator for selling a national treasure to the enemy, a far more serious crime than art forgery. When critics were asked to testify to the authenticity of the painting, they insisted it was a genuine Vermeer. Finally, to prove his innocence by demonstrating that he could forge a Vermeer, van Meegeren painted yet another fake Vermeer while under guard. Chemical tests and x-rays of other "Vermeers" confirmed van Meegeren's guilt. He was acquitted of collaboration—only to be convicted of fraud.

Sentenced to one year in prison, van Meegeren died in 1947, before the sentence could be carried out. Recently, during a new period of intense interest in Vermeer, there were two major exhibits of the faker's handiwork. Perhaps van Meegeren would feel he was having the last laugh.

33. Which of the following best tells what this passage is about?
- A. how to produce art forgeries
  - B. how art forgers differ from other criminals
  - C. how a skilled art forger nearly got away with fraud
  - D. forgeries of Dutch paintings
  - E. the difficulties of detecting art forgeries
34. Which of the following best describes van Meegeren's beliefs about art critics?
- F. They exaggerated the artistic merit of Vermeer's paintings.
  - G. They were overly worried about art forgery.
  - H. They did not recognize true talent when they saw it.
  - J. They believed his fakes were better than real Vermeers.
  - K. They did not appreciate Dutch art.

- 35.** Which of the following statements about Jan Vermeer is supported by the passage?
- A.** He did not become well-known until van Meegeren forged his paintings.
  - B.** He was van Meegeren’s invention and had never existed.
  - C.** He became wealthy by selling his works to museums and private collectors.
  - D.** He was considered a mediocre artist by art critics.
  - E.** Some of his paintings may have been lost.
- 36.** Van Meegeren differed from other art forgers in his ability to
- F.** copy Vermeer paintings.
  - G.** combine features from similar paintings by different artists.
  - H.** avoid prosecution for forgery.
  - J.** profit from his forgeries.
  - K.** paint forgeries without copying particular features.
- 37.** Why did van Meegeren admit that he was a forger?
- A.** The Germans had conducted chemical tests and x-rays that unmasked his forgeries.
  - B.** He wanted critics to appreciate his talents.
  - C.** Art critics had long suspected the forgeries.
  - D.** Forgery was a lesser crime than collaboration with the enemy.
  - E.** Vermeer himself was a forger, so van Meegeren had committed no crime.
- 38.** In line 12, why did the author put the word “discovered” in quotation marks?
- F.** Van Meegeren had created the paintings and only pretended to discover them.
  - G.** Van Meegeren was the first to realize that Vermeer was a great artist.
  - H.** Van Meegeren pretended that he had purchased the paintings from Vermeer himself.
  - J.** Van Meegeren had invented the painter Vermeer, so there were no real Vermeer paintings to discover.
  - K.** Van Meegeren deceived the critics into believing that the paints and canvases were from the seventeenth century.

CONTINUE ON TO THE NEXT PAGE ►



Archaeologists first succeeded in using tree-ring dating while excavating ancient Pueblo Indian villages in the southwestern United States during the 1920s. At that time, no one knew when the villages had been occupied, or for how long, but the logs used in the buildings provided a clue. Scientists had long known that trees add a new growth ring to their circumferences during each growing season. Drought or early frost results in little growth and narrow rings. Good growing years result in wide rings. Archaeologists knew that by matching identical patterns of wide and narrow rings in sections of two different logs, they could determine which log was older. For example, a log with a certain pattern of rings near its outside edge would indicate a specific series of good and bad growing seasons. This log would have been cut down before a log of comparable size that shows the identical pattern near its center.

But how could these ring patterns help determine the actual dates for the abandoned Pueblo villages? Archaeologists had already used the ring patterns of trees with overlapping lifetimes to establish a tree-ring chronology for the southwestern United States that went back to A.D. 1260. That work had been done in a Hopi village called Oraibi. Oraibi had been continuously inhabited since before the arrival of the first Spanish explorers in 1540.

That same team of archaeologists also developed a relative, or “floating,” chronology for the abandoned Pueblo villages by matching up the ring patterns of the various logs used in the buildings. With this “floating” chronology, the archaeologists could tell which logs were older and which were more recent. None could be precisely dated, since no log had a pattern of tree rings that matched any part of the established chronology. It was clear from this evidence, however, that the buildings must have been constructed before A.D. 1260.

Finally, continued excavations turned up a “key” beam. The outer ring pattern of the

key beam overlapped the earliest rings in the established chronology. Furthermore, its inner ring pattern matched the pattern formed by the most recent rings of the “floating” chronology. Thus, the chronology for the abandoned Pueblo villages could be known with certainty. Counting backward from the present, the archaeologists estimated that the villages had been occupied between A.D. 900 and A.D. 1300.

The tree rings also suggested **why** the villages had been abandoned. The rings for the years A.D. 1276 to 1299 were very thin, indicating a severe drought that lasted for 23 years. Most likely the villagers had left their homes to search for a more hospitable climate.

39. Which of the following best tells what this passage is about?
- A. how variations in weather conditions affect tree growth
  - B. recent breakthroughs in understanding Indian cultures
  - C. why the Pueblo villages were abandoned
  - D. how tree-ring dating can establish the age of archaeological findings
  - E. why tree-ring dating is the best method for determining dates
40. What was the importance of the “key” beam described in the fourth paragraph?
- F. It proved that trees of the same age would have identical tree-ring patterns.
  - G. It helped to disprove earlier theories regarding the abandonment of the villages.
  - H. It helped archaeologists to determine why the villages had been built at that time.
  - J. It explained why the Pueblo buildings had been constructed at that location.
  - K. It connected the “floating” chronology to the established chronology.

CONTINUE ON TO THE NEXT PAGE ►

41.

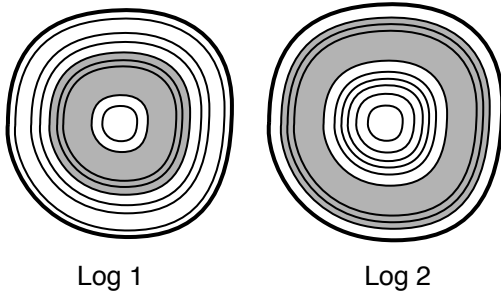

In the diagrams above, an identical ring pattern on logs from two trees has been shaded. Which of the following conclusions about these logs is best supported by the information in the passage?

- A. Log 1 was cut before log 2.
  - B. Log 2 was cut before log 1.
  - C. The two trees responded differently to the same growing seasons.
  - D. The tree from which Log 1 was cut was the faster-growing tree.
  - E. The tree from which Log 2 was cut was the faster-growing tree.
42. For which of the following would tree-ring dating be **most** useful?
- F. identifying the kinds of trees used to build the ancient Pueblo buildings
  - G. tracking the historical sequence of weather cycles in a region
  - H. investigating the reasons that Indians lived in specific areas
  - J. determining the length of the growing season in different areas of the world
  - K. determining how people built their villages

43. Why did the archaeologists conclude that the buildings in the abandoned Pueblo villages “must have been constructed before A.D. 1260” (lines 45-46)?

- A. The logs in those buildings did not share any ring patterns with the established chronology, which went back to that year.
  - B. The logs in those buildings had ring patterns in common with the logs used in Oraibi.
  - C. The villages were still inhabited when the Spanish explorers found them.
  - D. The villages were already abandoned when the Spanish explorers found them.
  - E. The people in those villages had moved to Oraibi.
44. According to the passage, what is the most likely reason that the Pueblo villages had been abandoned?
- F. The villages were destroyed by warfare between the Pueblo and Hopi people.
  - G. There were no more trees to build with.
  - H. A long drought prompted people to leave the area.
  - J. The villages had grown too large for their locations.
  - K. The villagers fled to escape the Spanish explorers.

CONTINUE ON TO THE NEXT PAGE ►

Most people—if they think about bubbles, suds, and lather at all—consider them to be fairly ordinary physical occurrences. But scientists have been studying foams, particularly aqueous (watery) foams, for more than 300 years. The phenomenon of foam creation is quite complex, and only recently have scientists begun to understand how foams are formed.

Aqueous foam is produced when a gas—air, for example—is dispersed within a liquid, such as water. However, a pure liquid produces an unstable froth, so a third ingredient must be added to stabilize the froth into foam. The most common stabilizers, or foaming agents, are soaps and proteins. These stabilizers are also called surfactants, or surface-active agents. Surfactant molecules chemically disturb the surface of the liquid, lowering its surface tension and creating a foam of bubbles, each encased in a watery film. The dispersing gas continues to build bubbles until the liquid is partially or completely converted to foam, with a surface area far greater than that of the original volume of liquid.

Foams have a characteristic life cycle. During the first stage, the liquid content is high and the foam is characterized by spherical bubbles of nearly uniform size, each with a relatively thick outer film of liquid. As the foam ages, the liquid drains away, and the foam “dries.” The bubbles are no longer spherical; they have become polyhedrons with multiple flat surfaces. Eventually, outside forces—usually evaporation or vibration—cause the film walls of the bubbles to collapse, and the foam disappears.

The soap foams of shampoo, bubble bath, and dishpan suds were developed largely to satisfy consumer expectations. Protein foaming agents create whipped cream and marshmallows. Still other foams have important practical applications. Perhaps best known of these is the foam used in fire extinguishers. It puts out oil or gasoline

fires by smothering them in a blanket of foam made of carbon dioxide bubbles stabilized by a protein-based surfactant. In general, these extinguishers have the advantage of minimizing the extensive water damage caused by more traditional fire-fighting methods.

Less well-known are the applications of foam technology to the recovery of oil from deep wells. Water is often present along with this energy-producing resource, and the water must be removed before the well can become productive. Drillers introduce a gas, along with an appropriate surfactant, into the well, and then pump out the resulting foam. Thus the water is removed, leaving a more productive oil well.

45. Which of the following best tells what this passage is about?
- A. the life cycle of an aqueous foam
  - B. how foam was discovered
  - C. industrial uses of aqueous foams
  - D. differences between surfactants and foaming agents
  - E. how aqueous foams are formed, and some of their uses
46. In which of the following locations would an aqueous foam be expected to disappear most rapidly?
- F. on the shelf of a working refrigerator with its door closed
  - G. aboard an airtight satellite filled with humid air
  - H. on a moving railroad train on a hot day
  - J. on a table in a research laboratory
  - K. in the darkened vault of a bank

CONTINUE ON TO THE NEXT PAGE ►

47. How does a surfactant contribute to the formation of an aqueous foam?
- A. It dissolves the gas in the liquid.
  - B. It changes the surface tension of the liquid.
  - C. It delays the formation of polyhedron bubbles.
  - D. It causes the bubbles to disappear.
  - E. It converts soap into foam.
48. Which of the following is characteristic of a “young” aqueous foam?
- F. spherical bubbles
  - G. polyhedral bubbles
  - H. bubbles with thin walls
  - J. “dry” foam, with liquid draining away
  - K. increased surface tension of the liquid
49. Why is foam better than plain water in fighting oil fires?
- A. It results in less water damage.
  - B. It is not flammable.
  - C. It does not evaporate.
  - D. Its bubbles form a film.
  - E. It promotes oil recovery.
50. Which of the following is **not** mentioned in the passage as an ingredient of dishpan suds?
- F. protein
  - G. water
  - H. soap
  - J. air
  - K. a surfactant

CONTINUE ON TO THE NEXT PAGE ►

# PART 2 — MATHEMATICS

*Suggested Time — 75 Minutes*

50 QUESTIONS

## GENERAL INSTRUCTIONS

Solve each problem. Select the **best** answer from the choices given. Mark the letter of your answer on the answer sheet. You can do your figuring in the test booklet or on paper provided by the proctor. **DO NOT MAKE ANY MARKS ON YOUR ANSWER SHEET OTHER THAN FILLING IN YOUR ANSWER CHOICES.**

### IMPORTANT NOTES:

- (1) Formulas and definitions of mathematical terms and symbols are **not** provided.
- (2) Diagrams other than graphs are **not** necessarily drawn to scale. Do not assume any relationship in a diagram unless it is specifically stated or can be figured out from the information given.
- (3) Assume that a diagram is in one plane unless the problem specifically states that it is not.
- (4) Graphs are drawn to scale. Unless stated otherwise, you can assume relationships according to appearance. For example, (on a graph) lines that appear to be parallel can be assumed to be parallel; likewise for concurrent lines, straight lines, collinear points, right angles, etc.
- (5) Reduce all fractions to lowest terms.

51.  $3.6 \div \frac{2}{3} =$

- A. 2.4
- B. 5.4
- C. 6
- D. 9
- E. 54

52.  $-2x(3y - 4z) =$

- F.  $-6xy - 8xz$
- G.  $-6xy + 8xz$
- H.  $-6xy - 4z$
- J.  $2xyz$
- K.  $24xyz$

53. Maria is now 16 years old. In 6 years, she will be twice as old as her brother is then. How old is her brother now?

- A. 5
- B. 6
- C. 8
- D. 11
- E. 12

CONTINUE ON TO THE NEXT PAGE ►

54.  $6.44 + 6.46$
- Consider the following two methods to estimate the sum above:
- Method I: Round each number to the nearest tenth, then add.
- Method II: Round each number to the nearest whole number, then add.
- By how much would the result of Method I be **greater** than the result of Method II?
- F. 0  
 G. 0.1  
 H. 0.9  
 J. 1  
 K. 12.9

55. If  $M$  and  $T$  are odd numbers, and  $M$  is a multiple of  $T$ , which of the following **must** be true?
- A.  $M + T$  is odd.  
 B.  $MT$  is even.  
 C.  $M - T$  is odd.  
 D.  $M \div T$  is even.  
 E.  $M \div T$  is odd.

56. The scale on a map is 1 inch = 10 miles. What is the distance, in inches, on the map between two towns that are  $m$  miles apart?
- F.  $\frac{m}{10}$   
 G.  $\frac{m}{5}$   
 H.  $5m$   
 J.  $10m$   
 K.  $m + 10$

57. There are 1,650 registered voters in Centerville. Of these,  $\frac{1}{3}$  were born between 1950 and 1979, inclusive. How many of the registered voters were born either **before** 1950 or **after** 1979?
- A. 550  
 B. 660  
 C. 825  
 D. 990  
 E. 1,100

58. Tien is making 5-letter security codes using only the letters M, N, P, Q, and R. She arranges the letters in a different order for each code, using every letter exactly once within each code. How many different codes can she make?
- F. 1  
 G. 5  
 H. 15  
 J. 120  
 K. 3,125

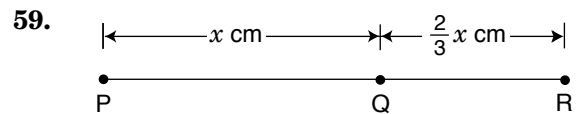

Point  $Q$  is on line segment  $\overline{PR}$ . If  $PQ = 9$  centimeters, how long is  $\overline{PR}$ ?

- A. 6 cm  
 B. 12 cm  
 C.  $13\frac{1}{2}$  cm  
 D. 15 cm  
 E. 18 cm

CONTINUE ON TO THE NEXT PAGE ►

60.

## 2004 SCHOOL DATA

	Average Number of Students per Teacher	Number of Classroom Teachers	Spending per Student
Alaska	17.2	7,800	\$10,000
Colorado	16.9	45,000	\$7,600
Dist. of Columbia	13.8	5,500	\$11,200
Hawaii	16.5	11,000	\$8,400
Indiana	16.9	60,000	\$8,000
Montana	14.4	10,300	\$7,600

Of the six locations listed above, what is the median spending per student?

- F. \$7,600
- G. \$8,000
- H. \$8,200
- J. \$8,800
- K. \$9,800

61. How much greater than 1.095 is the value obtained by rounding 1.095 to the nearest tenth?

- A. 0.005
- B. 0.5
- C. 1.005
- D. 1.1
- E. 5

62.

## MEAN ELEVATION OF CONTINENTS

Continent	Mean Elevation
North America	2,000 ft
South America	1,800 ft
Europe	980 ft
Asia	3,000 ft
Africa	1,900 ft
Oceania	1,000 ft
Antarctica	6,000 ft

After each elevation above is rounded to the nearest thousand feet, what is the **mode** elevation?

- F. 1,000 ft
- G. 2,000 ft
- H. 3,000 ft
- J. 6,000 ft
- K. 17,000 ft

63. A 24-foot-long pole is cut in half. One of these pieces is cut in half again. Finally, one of the shorter pieces is cut into thirds. Of these 5 cut pieces, what is the difference in length between the longest piece and **one** of the 3 shortest pieces?

- A. 2 ft
- B. 6 ft
- C. 10 ft
- D. 12 ft
- E. 22 ft

64. 12, 10, 2, 8, -6, 14, \_\_\_\_, ...

In the sequence above, each number (except the first two) is the difference between the two previous numbers. What is the seventh number in this sequence?

- F. -20
- G. -8
- H. 4
- J. 8
- K. 20

65. What is the value of

$$\left| \frac{1}{16} \right| \cdot |16| + |-16| + |16|?$$

- A. 1
- B. 3
- C.  $16\frac{1}{16}$
- D. 33
- E. 768

66. The ratio of Bettina's height to her sister's height is 7:6. If Bettina is 140 centimeters tall, how much taller is Bettina than her sister?

- F. 6 cm
- G. 10 cm
- H. 13 cm
- J. 20 cm
- K. 120 cm

CONTINUE ON TO THE NEXT PAGE ►

67. What is the greatest prime factor of 210?

- A. 5
- B. 7
- C. 10
- D. 21
- E. 105

68.

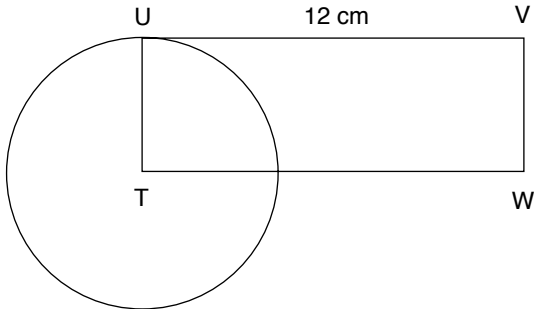

In the diagram above, T is the center of the circle, the circumference of which is  $8\pi$  centimeters. Point U is on the circle. What is the area of rectangle TUVW?

- F. 24 sq cm
- G. 36 sq cm
- H. 40 sq cm
- J. 48 sq cm
- K. 96 sq cm

69. What is the greatest common factor of 459 and 567?

- A. 3
- B. 9
- C. 17
- D. 27
- E. 51

70. Which statement is true?

- F. All equilateral triangles are congruent.
- G. All equilateral triangles are similar.
- H. All rectangles are congruent.
- J. All rectangles are similar.
- K. All squares are congruent.

71. The sales of hot drinks are roughly a linear function of outdoor temperature. If a vendor sells 200 cups when the outdoor temperature is  $70^\circ$ , and 440 cups when the outdoor temperature is  $50^\circ$ , how many cups can the vendor expect to sell if the outdoor temperature is  $55^\circ$ ?

- A. 260
- B. 380
- C. 435
- D. 500
- E. 520

72. A certain type of bamboo blooms for 1 week once every 17 years. This type of bamboo bloomed in 1807. How many times did it bloom between 1820 and 2011, inclusive?

- F. 5
- G. 6
- H. 10
- J. 11
- K. 12

73. 
$$\frac{(-1)^2 + (-2)^3 + (-3)^4}{(-1)^4 + (-2)^3 + (-3)^2} =$$

- A. 0
- B. 1
- C. 5
- D. 9
- E. 37

74. Survey results indicate that between 70% and 80% of high school students have their own cell phones. If these results apply to a high school of 900 students, what is the maximum number of students who do **not** own cell phones?

- F. 180
- G. 270
- H. 370
- J. 720
- K. 828

CONTINUE ON TO THE NEXT PAGE ►



---

75. If Seung is now  $y$  years old and Jackson is 3 years older than Seung, what was Jackson's age 8 years ago?

- A.  $y - 11$
- B.  $y - 3$
- C.  $y - 5$
- D.  $y + 11$
- E.  $3y - 8$

---

76. On a number line, what is the midpoint of a line segment beginning at  $-2$  and ending at  $\frac{2}{5}$ ?

- F.  $-\frac{7}{10}$
- G.  $-\frac{4}{5}$
- H.  $-\frac{1}{5}$
- J. 0
- K.  $1\frac{1}{5}$

---

77. Yan has 48 coins, consisting of a mix of nickels and dimes. The total value of these 48 coins is \$3.90. How many more dimes than nickels does Yan have?

- A. 10
- B. 12
- C. 18
- D. 22
- E. 30

---

78. If the side of a square and the diameter of a circle are equal in length, what is the ratio of the perimeter of the square to the circumference of the circle?

- F.  $\frac{1}{1}$
- G.  $\frac{\pi}{2}$
- H.  $\frac{2}{\pi}$
- J.  $\frac{\pi}{4}$
- K.  $\frac{4}{\pi}$

---

79. A used car is sold for \$5,000. The buyer pays \$400 for the down payment. What fraction of the sale price is the down payment?

- A. 0.0125
- B. 0.08
- C. 0.125
- D. 0.4
- E. 0.8

---

80. A particular type of plastic weighs 0.035 ounces per cubic inch. What is the weight of a stack of 50 rectangular sheets of this plastic if the stack measures 5 inches by 10 inches by 20 inches?

- F. 0.000035 oz
- G. 0.7 oz
- H. 3.5 oz
- J. 35 oz
- K. 1,750 oz

---

81. A painter needs to paint a circular region with a radius of 3 feet. The painter has only enough paint to cover 25 square feet. About how many square feet of the region **cannot** be painted?

- A. 2.7 sq ft
- B. 3.3 sq ft
- C. 6.2 sq ft
- D. 18.8 sq ft
- E. 28.3 sq ft

---

82. Gloria receives a 15% commission on her sales. For the last three-month period, Gloria received a commission of \$12,000. What were her sales for this period?

- F. \$13,800
- G. \$68,000
- H. \$80,000
- J. \$92,000
- K. \$800,000

CONTINUE ON TO THE NEXT PAGE ►

83.

$x$	$y$
1	$-a - \frac{b}{2}$
2	$-\frac{b}{3}$
3	$a - \frac{b}{4}$
4	$2a - \frac{b}{5}$

Based on the table above, which of the following best represents the value of  $y$  when  $x = 0$ ?

- A.  $-2a - b$
- B.  $-b$
- C.  $-\frac{a}{2}$
- D.  $-2a$
- E.  $-\frac{a}{2} - b$

84. Daquan sold  $x$  hot dogs. Caitlyn and Daquan together sold  $5x - 2$  hot dogs. In terms of  $x$ , how many hot dogs did Caitlyn sell?

- F.  $\frac{x}{5} - 2$
- G.  $5x - 1$
- H.  $6x - 2$
- J.  $4x + 2$
- K.  $4x - 2$

85. For house sales, a certain real estate agent charges a commission of 3% of the house price for prices less than \$200,000, and 2.5% of the house price for prices of \$200,000 or more. How many more dollars does the agent earn on a price of \$199,000 than on a price of \$201,000?

- A. \$94.50
- B. \$945
- C. \$1,000
- D. \$1,055
- E. \$2,000

86.  $r = 3m = 4n = 10p$

If  $m$ ,  $n$ , and  $p$  are positive integers, what is the **least** possible value of  $r$ ?

- F. 1
- G. 10
- H. 17
- J. 60
- K. 120

87. In the set of all integers from 4 to 81, inclusive, how many are multiples of 2 or 7 or both?

- A. 34
- B. 39
- C. 45
- D. 50
- E. 55

88. If  $\frac{3t - s}{4} = 8s$ , what is the value of  $s$  in terms of  $t$ ?

- F.  $\frac{t}{2}$
- G.  $\frac{t}{3}$
- H.  $\frac{t}{4}$
- J.  $\frac{t}{7}$
- K.  $\frac{t}{11}$

89. Simplify the expression

$$r \left[ s \left( \frac{r+s}{r-s} \right) \left( \frac{r-s}{r+s} \right) \right], \text{ where}$$

$r \neq s$  and  $r \neq -s$ .

- A.  $rs$
- B.  $s$
- C.  $rs(r+s)(r-s)$
- D.  $(r+s)(r-s)$
- E. 1

CONTINUE ON TO THE NEXT PAGE ►

90. Between which two consecutive positive integers is  $\sqrt{6^2 + 7^2}$ ?

- F. 6 and 8
- G. 8 and 9
- H. 9 and 10
- J. 12 and 14
- K. 36 and 49

91.

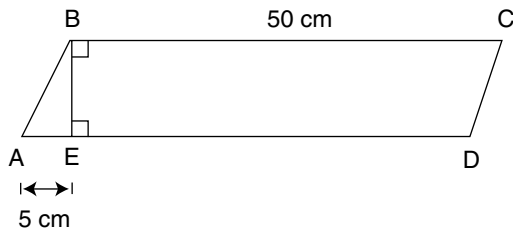

What is the area of parallelogram ABCD if the area of triangle ABE is 25 square centimeters?

- A. 140 sq cm
- B. 150 sq cm
- C. 250 sq cm
- D. 500 sq cm
- E. 550 sq cm

92. How many minutes are in 2.35 hours?

- F. 133 min.
- G. 138 min.
- H. 140 min.
- J. 141 min.
- K. 155 min.

93. A group of potential voters was asked whether or not they were in favor of Proposition A and Proposition B on the ballot. Of this group, 65% were in favor of Proposition A, and 72% were in favor of Proposition B. If 3% of the total group were not in favor of either proposition, what percent were in favor of **both** propositions? (Assume that 100% of the group responded and there were no undecided voters.)

- A. 25%
- B. 28%
- C. 32%
- D. 35%
- E. 40%

94.

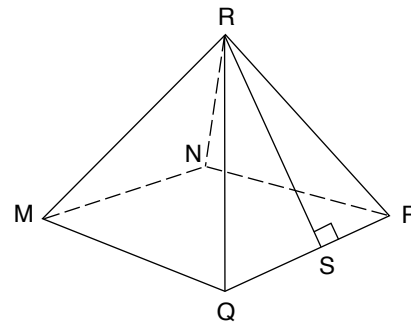

For the pyramid above, each triangular face has the same area, and the base, MNPQ, is a square that is 8 centimeters on a side. If RS is 6 centimeters, what is the surface area of the pyramid, **excluding** the base?

- F. 48 sq cm
- G. 96 sq cm
- H. 128 sq cm
- J. 160 sq cm
- K. 192 sq cm

95.

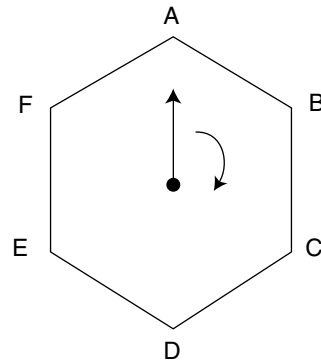

ABCDEF is a regular hexagon. The arrow in it rotates at a constant rate of 5 revolutions per minute. If the arrow points to A for the first time at 0 seconds as shown, how many **seconds** will elapse before the arrow points to B for the eleventh time?

- A. 12 sec
- B. 110 sec
- C. 120 sec
- D. 122 sec
- E. 134 sec

CONTINUE ON TO THE NEXT PAGE ►

96.  $(3m + 2n) - (2m - 3n) + k = 0$

For any value of  $m$  and  $n$ , what is the value of  $k$  in the equation above?

- F.  $-m - 5n$
- G.  $-m + n$
- H. 0
- J. 1
- K.  $m + 5n$

97.

Position	Even integer
1	0
2	2
3	4
4	6
⋮	⋮
500	$x$

The beginning of a list of even integers is shown in the table above. What will the 500th number on the list be?

- A. 500
- B. 994
- C. 996
- D. 998
- E. 1,000

98. Firefighters sprayed a 9-inch-thick layer of foam over a burning rectangular region 10 yards wide and 50 yards long. What volume of foam was used on the fire?

- F. 55 cu yd
- G. 125 cu yd
- H. 250 cu yd
- J. 450 cu yd
- K. 4,500 cu yd

99. 5, 6, 7, 8, 9

If  $\frac{x + 7}{x - 7}$  is a whole number, how many of the numbers listed above **cannot** be a value of  $x$ ?

- A. 0
- B. 1
- C. 2
- D. 3
- E. 4

100. SCORES ON BIOLOGY TEST

Section	Lowest Score	Range
I	65	28
II	62	25
III	67	22

Mr. Blake's biology class is divided into three sections. The same test was given to each section. The table above shows both the lowest score and the range of scores on this test for each section. What is the **overall** range of all scores in all three sections?

- F. 25
- G. 27
- H. 28
- J. 31
- K. 34

THIS IS THE END OF THE TEST. IF TIME REMAINS, YOU MAY CHECK YOUR ANSWERS TO PART 2 AND PART 1. BE SURE THAT THERE ARE NO STRAY MARKS, PARTIALLY FILLED ANSWER CIRCLES, OR INCOMPLETE ERASURES ON YOUR ANSWER SHEET. ■



▶▶▶ Scrambled Paragraphs

**Paragraph 1 (TQURS)**

The given sentence says that Aztec culture and traditions are described in a document called the Codex Mendoza. T is next; it is an example of one of the Aztec traditions, naming a newborn child. The pronoun “it” in T refers to the Codex in the given sentence. Either of two sentences, Q or U, could logically follow, explaining how baby boys and girls were given names. Q, which describes how boys were named, logically follows T. U, describing how girls were named, contains the phrase “on the other hand,” implying that it follows a sentence with contrasting information. The contrasting information is naming boys (vs. naming girls), so U must follow Q. R is next, using the word “also” to introduce another Aztec tradition, the placement of implements in an infant’s hands. S follows R by giving examples of the implements given to girls and boys.

**Paragraph 2 (RQTUS)**

The given sentence names Crane’s novel *The Red Badge of Courage*. Either Q or R could grammatically follow. Create one paragraph starting with Q and another starting with R, and compare them. Q gives the full name of Crane’s first novel, *Maggie: A Girl of the Streets*, and comments that it was not successful. Sentence T gives further background information about *Maggie* (a shortened title must be preceded by the full title)—that Crane borrowed money to publish it. The loan is mentioned again in sentence U, plus a comment that Crane gave away copies of the book. S concludes the paragraph with another of Crane’s unsuccessful strategies to sell the book. QTUS is now a logical and grammatical four-sentence paragraph about Crane’s first novel. R remains, but it cannot follow QTUS, because the unnamed successful second novel in R cannot be *Maggie*. That order did not work, so create a new paragraph with R following the given sentence. R logically and grammatically leads to Q; the success of Crane’s second novel in R is contrasted with the failure of his first novel in Q. Sentences TUS logically follow Q, as already explained, to create a coherent and well-organized paragraph.

**Paragraph 3 (SRUQT)**

The given sentence is a plausible statement about nature preserves, but its opening phrase (“It might be assumed that”) suggests that there might be exceptions. S begins with the word “But,” implying opposition to the previous sentence, and it provides an exception to the rule, a nature preserve called Shooter’s Island located near New York City. The next sentence is more difficult to place and can be selected by the process of elimination. Sentences Q, T, and U do not follow S grammatically or logically. Only R can follow S—although it does not

have a close relationship with S, it does provide a further definition of Shooter’s Island (a “45-acre island”). This is another example of a paragraph that is solved by viewing it as a coherent whole, more than the connections between individual sentences. The next three sentences follow more logically. R mentions that Shooter’s Island became a dumping ground, and U follows with the discovery that the abandoned docks there now sheltered water birds. The discovery was made by a pair of bird-watchers who had followed a water bird to a thriving bird colony on the island (Q). T concludes the paragraph by describing how those birds “commute” between the island and the city.

**Paragraph 4 (TRUQS)**

Either sentence R or T could follow the given sentence. Try both possibilities and compare the results. When R follows the opening sentence, it continues the discussion of volcanoes, including Kilauea, the most active volcano in the world. U follows R with its reference to “that volcano,” referring to Kilauea, and further describes Kilauea’s activity. U also names Hawaii Volcanoes National Park. “In the same park” (in Q) logically follows that reference. Q mentions a second volcano by name, Mauna Loa. S must follow Q because it refers to two volcanoes (“Both of these are shield volcanoes . . .”). But the remaining sentence, T, ends the paragraph on an awkward note. Placing T at the end means that the definition of the paragraph’s topic (volcanoes) appears after, not before, further discussion of the topic. RUQST is not well-organized and cohesive.

For comparison, place T immediately after the given sentence instead of R. Now, the given sentence is followed with another reference to Vulcan, and the definition of a volcano appears early in the paragraph. The logic and flow of thought that formed RUQS remains the same. TRUQS has created a well-organized, cohesive paragraph, and it is the only correct answer.

**Paragraph 5 (UQSRT)**

Astronomer Dr. Philip Stooke is introduced in the given sentence as a mapmaker of the moon. Q and U both seem to follow the given sentence, but “before that date” in Q has no referent in the given sentence. U contains a date (1505), so Q must logically and grammatically follow U. Stooke’s examination of historical records in Q led to his discovery of a photograph of a carving from a pre-historic tomb (S). So far the order is UQS. R links the drawing of the tomb carving to a picture of the moon, and it logically follows S. The paragraph ends with Stooke’s conclusion in T that the carving is an ancient map of the moon. Some test-takers might order the sentences UQSTR, but in that order, Stooke’s conclusion (that the

carving is a map of the moon) precedes the evidence for his statement (the fact that the carving matches a map of the full moon). The correct order places Stooke’s conclusion *after* the evidence is presented.

▶▶▶ Logical Reasoning

11. (C) Draw a diagram with four spaces beside Quil, using the initials D, N, S, and T to represent the names of the planets. Needer is closest to Quil (Statement 1), so write “N” in the first space. The orbit of planet Sly is farthest from the orbit of Needer (Statement 3), so write “S” in the last space.

Quil                      N    \_\_\_    \_\_\_    S

We can stop here. The question asks for the planet that travels fastest, which is also the planet farthest away from Quil. That planet is Sly (Option C).

12. (J) On your scratch paper, draw a diagram with the word “highest” at the top. Write the numbers 1 through 4 to represent the positions of the four people in the flying contest.

HIGHEST  
1  
2  
3  
4

Neither statement places a contestant in a definite position. Rather, they give information about contestants relative to each other: Alice’s airplane flew higher than Huang’s, and Mariah’s did not fly as high as Alice’s. From this information you can infer the following:

HIGHEST	
Statement 1	Statement 2
???	???
Alice	Alice
???	???
Huang	Mariah
???	???

The question marks are placeholders for other contestants. (The diagram shows placeholders for 5 contestants because there is no information to determine anyone’s exact position. However, there are only 4 contestants: Alice, Sidney, Huang, and Mariah.) Notice that no information is given about Sidney’s airplane. For a question like this, in which all of the information is relative, it is best to evaluate each option and determine which **must** be true. Options F, G, H, and K **might** be true, but not enough information is given to conclude that any of

them **must** be true. Only Option J **must** be true. If Sidney finished second, then Sidney finished ahead of Huang and Mariah, and Alice won. The diagram makes this clear. Even though Huang and Mariah’s exact positions are unknown, the question can still be answered correctly.

13. (C) Draw the following diagram on your scratch paper. (Six years are shown because six is the largest option.)

Year	1	2	3	4	5	6
Volleyball						
Soccer						
Basketball						

The question does not specify the order in which Sequina played each sport. Since she played soccer longer than the other sports, start with soccer. Put an X under years 1, 2, and 3, to represent Sequina’s three years in that sport.

Year	1	2	3	4	5	6
Volleyball						
Soccer	X	X	X			
Basketball						

Sequina also played volleyball and basketball for two years each, and she never played more than two sports during the same year. One possibility is that she played volleyball during her first and second years. After “volleyball,” put an X under years 1 and 2. Since Sequina never played more than two sports at a time, she could not have started basketball until year 3. After “basketball,” put an X under years 3 and 4.

Year	1	2	3	4	5	6
Volleyball	X	X				
Soccer	X	X	X			
Basketball			X	X		

This is one possible arrangement, and it requires four years. All other possibilities require at least four years. Option C is correct.

14. (J) According to statement 1, the towns of Elmont, Lendle, and Richland are connected by Highway 14. Draw a diagram to show this relationship.

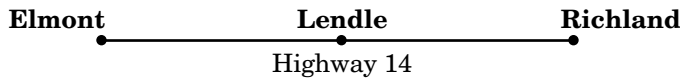

From the question, we know that Highway 14 is closed from Elmont to Richland. This stretch of highway includes the town of Lendle.

Statement 2 says that the town of Mopley is connected to Lendle, but does not specify *how* it is connected. Mopley could be connected to Lendle by another road (not named), or it could be on Highway 14 between either Elmont and Lendle or Richland and Lendle.

Options F and K might or might not be true. Not enough information is provided to determine whether the town of Mopley is flooded, or whether Mopley can be reached directly from Elmont. Nor can we determine whether Options G or H are valid. Highway 14 connecting Elmont and Richland is flooded, but we cannot determine whether the towns are flooded. Only Option J is valid. Highway 14 between Elmont and Richland is closed because of flooding, so no one can drive to Lendle on Highway 14.

15. (B) Draw a grid to illustrate who won each prize. An X indicates who did **not** receive a prize. According to Statement 2, Michael did not win the computer.

	Trip	Television	Computer
Luis			
Michael			X
Nadia			

The question asks which option makes it possible to determine who won each prize, that is, to fill in the rest of the grid. For each option, mark the information on the grid. Are you able to determine who won each prize? If not, erase the marks and evaluate the next option. For example, mark the information for Option A, writing “yes” to indicate who won a prize, and filling in X’s wherever you can.

	Trip	Television	Computer
Luis	X		
Michael	Yes	X	X
Nadia	X		

Option A does not allow us to figure out who won the television set and the computer, so it cannot be correct. Only Option B allows us to determine who won each prize.

	Trip	Television	Computer
Luis	X	Yes	X
Michael	Yes	X	X
Nadia	X	X	Yes

16. (F) According to the question, every millworker in Hoxie is over six feet tall and good at math. There must be other people in Hoxie besides millworkers, but we do not know how tall they are, or whether they are good at math. Option F must be true. At least some people in Hoxie (the millworkers) are over six feet tall and good at math. Options G, H, J, and K **might** be true, but we cannot conclude that they **must** be true.

17. **and 18.** *These directions differ from the directions for the code in Sample Form A. They state that the position of a letter is **never** the same as that of the word it represents. For example, in the first sentence, L cannot represent “Marie.” To answer these questions, you need not find out what every letter represents.*

17. (E) The word “juice” appears only once in the code, in the fourth sentence, so the letter representing “juice” must appear only in the fourth sentence. W can be ruled out because it appears in two of the statements and is in the same position as “juice.” N cannot be correct because it also appears in the second sentence, which does not contain the word “juice.” The letters Y and X appear only in the fourth sentence, but neither letter can be ruled out. Thus, the correct answer is E, “Cannot be determined from the information given.”

18. (K) The letter U appears only in the second sentence. Thus, the word it represents must appear only in the second sentence. Option F (“Sean”) is incorrect because it appears in the same position (first) as the letter U, and the directions state that the position of a letter can never be the same as the word it represents. Options G, H, and J can be ruled out because they appear in other sentences as well as the second sentence. Option K (“soda”) appears only in the second sentence and it does not appear in the same position as the letter U, so it is correct.

19. (E) A snobble is not defined, but it is not necessary to know what it is in order to answer the question. We know only that it can be described in terms of speed, weight, and color. Draw a diagram to illustrate the relationship among those qualities described in the question.



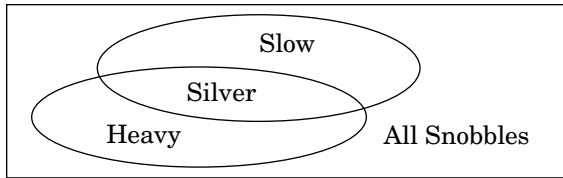

Options A, B, C, and D are not supported by the diagram. For example, Option A, “All snobbles are silver,” is not correct. The diagram shows that some snobbles are silver, but does not show that they are all silver. Option E is correct. A gold snobble cannot be heavy and slow, because every snobble that is heavy and slow is silver.

**20. (F)** This question requires you to solve two relationships: matching each troll with a colorful characteristic, and putting the trolls in order. Start by matching the trolls and their characteristics. According to Statement 1, Snowflake has white hair. According to Statement 3, Gretchen has purple ears. Statement 2 states that Banto did not have green eyes, so Holly must have the green eyes. This leaves Banto with the red teeth.

Troll	Green Eyes	Purple Ears	Red Teeth	White Hair
Banto	no		yes	
Gretchen		yes		
Snowflake				yes
Holly	yes			

Now, put the trolls in order. From Statements 1 and 2, we can conclude that Banto was in front of Snowflake and behind Gretchen. The question says that Holly (“green eyes”) was behind Gretchen. Thus, every troll is behind Gretchen, which is Option F.

## ▶▶▶ Reading

### ▶ Beavers

**21. (A)** The passage gives examples of how beavers affect their environment by cutting down trees and building dams, which in turn changes the landscape and the plants and animals that live there. Option A summarizes this point. Options B, C, D, and E are true statements, but they are details, not the theme of the passage.

**22. (G)** This complex question asks how changes in insect and plant life in a beaver pond result from something else, or, in other words, what causes the changes in insect and plant life in a beaver pond. Lines 24-31 explain that the changes in insect and plant life are the result of changes in the water temperature (warmer) and flow of

water (slower) in the pond. Thus, the correct answer is Option G. Options F and J might sound logical but are not mentioned in the passage. Option H is related to the question, but it incorrectly attributes the changes in the kinds of animals as the cause, not the result, of changes in insect and plant life. Option K refers to an abandoned dam, not an intact dam in a pond, so it cannot be correct.

**23. (E)** The beaver trapping in Wyoming is mentioned only in the final paragraph. The purpose for trapping and moving beavers is to encourage beavers to build dams that will halt soil erosion (lines 58-59), which is Option E. Options A and D are not mentioned in the passage. Option B might seem correct at first, but it refers to beavers causing soil erosion, not halting it. Option C is mentioned (lines 48-50) but not as the purpose of beaver trapping in Wyoming.

**24. (G)** This is an inference question. The correct answer is supported by the passage but is not directly stated. The question asks about the appearance of a recently abandoned beaver pond. Abandoned ponds are mentioned in lines 40-43, which say that beavers abandon a pond when the supply of desirable trees has run out. Notice that the description of these abandoned ponds (collapse of dams, transformation of landscape) is “long after the beavers have left” (lines 45-46), not recently abandoned. Option F, “the effects of severe erosion,” is incorrect because a recently abandoned pond would still have a dam, which would slow erosion, not cause it. Option K can be ruled out because the passage says nothing about the building of new beaver dams near abandoned beaver ponds. Regarding Option J, lines 21-23 state that several beavers at work can soon open up the forest area around a pond to sunlight. This fact rules out the possibility of dark, dimly lit forest land around a recently abandoned dam. The first sentence of the fourth paragraph says that beavers selectively cut the deciduous trees on stream banks, allowing evergreens to take over the area. Thus, Option H is ruled out; the mature deciduous trees must all be gone, or the beavers would not have left. Option G is correct. The evergreen trees around the pond are left undisturbed, and they gradually take over the area (lines 39-40).

**25. (E)** A comeback is a recovery or a return to a former condition. “This remarkable comeback” in line 13 must refer to a previously mentioned recovery of some kind. The first paragraph describes the beaver’s near-extermination, followed by a greatly increased population. The “comeback” must refer to a recovery in the beaver population, which is Option E. Options A, B, C, and D are mentioned in the passage, but not in reference to a comeback.





**26. (H)** The amount of wood that a beaver can cut down in a year is mentioned in lines 18-20. This sentence is followed by examples of how beavers change their environment (the formation of a pond, shift in water nutrients, and so on), including the amount of wood they cut down. The correct answer is Option H. None of the other options relates to the amount of wood cut down.

► **Old Man of the Mountain**

**27. (E)** Look at the theme of each paragraph. The first paragraph describes what the Old Man of the Mountain looked like. The second paragraph discusses its history. The third, fourth, and fifth paragraphs describe attempts to stabilize the monument, and the sixth paragraph discusses its collapse in 2003. The final paragraph describes memorials to the Old Man. Now look at the answer choices. Options A and B can be ruled out because each refers to only one of the seven paragraphs in the passage. Option C is mentioned in only three of the seven paragraphs, and Option D is impossible because the Old Man no longer exists. Option E is correct. It summarizes the main points of the passage—the history of the monument, attempts to stabilize it, its eventual collapse, and how it is remembered.

**28. (G)** The correct answer is found in lines 5-9, which explain that the Old Man looked like a random heap of stones from most viewpoints. The most likely reason that European-Americans had not seen the Old Man was that they had not yet stood at the correct viewpoint (Option G). Option F is ruled out because Europeans had lived in the area since the early 1600s (lines 17-19). Option H is incorrect; the Old Man was formed about 10,000 years ago (lines 12-14) and was the subject of Native American legends since the early 1600s (lines 17-20). Option J has nothing to do with the question, and Option K cannot be correct because the existence of the rock formation was never in doubt.

**29. (C)** The cause of the collapse is given in lines 56-60, and the correct answer is Option C, “water freezing and thawing in the cracks over centuries.” Option A might seem true, given the harshness of New Hampshire winters, but the passage is clear that “centuries of weathering and temperature extremes” (lines 54-55), were the cause, *not* the weight of ice and snow. Options B, D, and E are not mentioned in the passage.

**30. (F)** The hidden cave is mentioned in the fifth paragraph. An engineering study had shown that the rock formation consisted of five granite layers balanced atop one another. The paragraph concludes, “Surprisingly, the Old Man had balanced on its chin for many years.” One would not expect a rock formation balancing on its “chin” to remain in place for centuries, suggesting that the formation was not as stable as it appeared, which is Option F. The writer did not mention the cave to demonstrate how ice enlarges cracks (which is the subject of the next paragraph). Nor is the cave mentioned to explain why turnbuckles were installed (to close the cracks) or explain how the profile was formed (mentioned in the second paragraph). Option J contradicts information in the fifth paragraph.

**31. (A)** The importance of the Old Man as a symbol of New Hampshire, the Granite State, is discussed in the fourth paragraph. Lines 36-38 state, “Its [New Hampshire’s] people have always taken pride in their state’s rocky geography and their own strength and independence.” Option A, referring to the ruggedness of the land and people, restates that idea. None of the other options is supported by the passage. Option D might be attractive since the rock formation existed for centuries, but the passage is clear that it was not “well-balanced,” nor does it describe the state in those terms.

**32. (J)** The Old Man used to be at the top of Cannon Mountain (lines 14-15). The mountaintop is now a nondescript rock slope (lines 60-61), the word “nondescript” implying that no hint of the Old Man formation remains. The best answer is Option J, “Only random-looking rock formations remain.” There is no evidence in the passage to support Options F or G. Option H is incorrect because the museum was built at the base, not the top, of the mountain (lines 72-73). The proposed replica of the face was not implemented (lines 69-72), ruling out Option K.

► **Van Meegeren**

**33. (C)** The main theme of the passage is the career of Han van Meegeren. Options A and E are important details, but not main ideas. Option B is not mentioned at all. Option D is too broad; the passage is about Vermeer forgeries, not forgeries of Dutch paintings in general. Option C is best: “how a skilled art forger nearly got away with fraud.” It neatly sums up van Meegeren’s career, including his success and his downfall.



**34. (H)** This is an inference question. The correct answer is based on information in the passage but not directly stated. Van Meegeren’s beliefs about art critics are discussed in lines 3-9. Option F might sound promising, but it does not answer the question. The question asks about van Meegeren’s beliefs about art critics, not art critics’ opinions of the artistic merit of Vermeer’s paintings. Option G is incorrect; the critics did not seem worried about art forgery. Option H is best supported by the passage. Van Meegeren was angered by the critics’ rejection of his work, believing that they did not appreciate his talent. Option J is appealing at first, but the passage never compared the quality of van Meegeren’s fakes with real Vermeers. Option K cannot be true because the art critics considered Vermeer, a Dutch artist, to be a great master painter.

**35. (E)** Read each option before deciding which is best supported by the passage. Options A and B are false, since Vermeer was considered a master painter before van Meegeren’s hoax, and there was never any doubt of Vermeer’s existence. Options C and D are true about van Meegeren, not Vermeer. The passage suggests that Vermeer may have created paintings that have since been lost (line 13), which is Option E.

**36. (K)** The question asks you to compare van Meegeren with other art forgers. Option F was not discussed in the passage. Option G misstates the information in lines 18-20. Van Meegeren was eventually prosecuted for forgery, ruling out Option H. He profited from his forgeries (Option J), but that did not distinguish him from other art forgers. Option K is best. According to the passage, van Meegeren created a series of paintings that mimicked Vermeer’s style without duplicating specific details (lines 24-26).

**37. (D)** Option A is ruled out because the chemical tests and x-rays were conducted *after* his admission, and they were conducted by Dutch, not German, investigators. Option B is a true statement but it does not answer the question. Art critics insisted that the fake Vermeer was authentic, ruling out Option C. Option D is correct because lines 52-54 say, “selling a national treasure to the enemy [was] a far more serious crime than art forgery.” Finally, Option E cannot be correct because the passage never states or hints that Vermeer himself was a forger.

**38. (F)** Carefully read the sentences surrounding the quoted word (lines 9-14). “Discovered” is in quotation marks because the discovery was part of the hoax. Option F best restates that idea. Vermeer was already

considered a great artist, ruling out Options G and J, and Vermeer lived in the seventeenth century, long before van Meegeren’s lifetime, eliminating Option H. Option K doesn’t answer the question.

► **Pueblo**

**39. (D)** Option A cannot be the theme of the reading passage because only the first paragraph discusses how weather conditions affect tree growth. Option B, Indian cultures, is too broad to be the theme of the passage, which focuses on Pueblo and Hopi villages. The reason for the abandonment of the Pueblo villages (Option C) is mentioned only in the last paragraph, so it is not the theme of the entire passage. Option D, “how tree-ring dating can establish the age of archaeological findings,” offers a good summary of the entire passage, which explains the science of tree-ring dating, followed by several examples. Option E cannot be correct. The passage does not mention any other dating methods, nor does it claim that tree-ring dating is the best method for determining dates.

**40. (K)** The “key” beam is discussed in lines 47-55. This question requires you to understand the established chronology (line 50) and “floating” chronology (line 53) and to draw an inference about the “key” beam, based on information in the passage. Option F is a true statement, but it does not explain the importance of the “key” beam. The passage does not mention earlier theories about the abandonment of the villages, or why they had been built at certain times or at particular locations, ruling out Options G, H, and J. Option K is correct. The “key” beam, with its overlapping ring patterns of the established and “floating” chronologies, allowed archaeologists to connect the two chronologies.

**41. (B)** The two trees in the question share an identical pattern of a very wide band followed by two narrow bands, showing that both trees were alive during that three-year period, although they were planted and cut at different times. Options A and B can be evaluated by assigning arbitrary years to the three shaded rings—for example, 10, 11, and 12. (It does not matter what numbers you choose, as long as they are used consistently.) Counting out from the shaded rings, Log 1 was cut in the year 16, while Log 2 was cut in the year 13. Thus, Log 2 was cut before Log 1 (Option B). Option C contradicts the reasoning behind tree-ring dating and cannot be correct.

There is no way to determine which log came from the faster-growing tree, since the trees were different ages and cut at different times, ruling out Options D and E.



**42. (G)** This inference question requires you to choose the correct answer based on information that is not directly stated. Evaluate each option to determine whether tree-ring dating would be useful for that purpose. The passage gives no information whether types of trees can be identified using tree-ring dating, so Option F is not correct. Lines 10-12 indicate that “tracking the historical sequence of weather cycles in a region” (Option G) is both possible and useful using tree-ring dating. Lines 62-65 also support Option G. Read the remaining options to make sure that Option G is the best answer. The reasons why Indians lived in specific areas, or why they built their villages, cannot be answered by tree-ring dating, ruling out Options H and K. Comparing growing seasons around the world is not possible (Option J), since only one part of the world, the southwestern United States, is discussed with relation to tree-ring dating.

**43. (A)** The quotation is from lines 45-46, but we must refer to several parts of the passage to answer the question. The second paragraph states that archaeologists had established a continuous tree-ring chronology going back to A.D. 1260, based on ring patterns of trees with overlapping lifetimes (the “established” chronology). The third paragraph, where the quotation appears, describes the development of a “floating” chronology that indicated which logs were older and which were more recent, but did not overlap the established chronology. The fact that they did not overlap implies that the floating chronology preceded the established chronology, which is Option A. Option B cannot be true because the logs used in Oraibi went as far back as A.D. 1260, but no further. The remaining options do not explain the archaeologists’ conclusion.

**44. (H)** The abandonment of the Pueblo villages is mentioned in lines 24-25 and line 36, but only in the context of determining when the villages were occupied. The reason for their abandonment is not brought up until the last paragraph, which suggests that the villagers left their homes to find a more hospitable climate (lines 63-65). This is restated in Option H, the correct answer. Options F, G, J, and K might sound reasonable, but there is no evidence in the passage that suggests they are true.

### ► Foams

**45. (E)** Options A and C are important details, but they are not the main themes of the passage. Option B is not discussed, and Option D does not make sense—the terms “surfactants” and “foaming agents” are synonymous. Option E is the best answer. “How aqueous foams are formed, and some of their uses” provides a good summary of the passage from beginning to end.

**46. (H)** The characteristic life cycle of an aqueous foam is outlined in the third paragraph. The foam disappears when “outside forces—usually evaporation or vibration” cause the bubbles to collapse (lines 36-39). Check the options to see which one best describes such a situation. The only option that involves movement, which causes vibration, is Option H. The other options describe stationary situations.

**47. (B)** The role of the surfactant in the formation of aqueous foam is discussed in the second paragraph. Surfactants are necessary to stabilize an aqueous foam. They work by lowering the surface tension of a liquid (lines 19-21), which is Option B. Option A is not mentioned in the passage (although dispersal of a gas in the liquid is an important point). Options C and D are stages in the life cycle of a foam, not the results of a surfactant. Option E might look appealing because it refers to the formation of foam, but it incorrectly states that soap, a surfactant, is converted into foam.

**48. (F)** The “life cycle” of aqueous foam is outlined in the third paragraph. A “young” foam occurs early in the life cycle, in which foam is characterized by “spherical bubbles of nearly uniform size, each with a relatively thick outer film of liquid” (lines 30-32). Only Option F, “spherical bubbles,” is characteristic of a “young” foam. Options G, H, and J are characteristics of later stages. Option K is not part of the foam life cycle.

**49. (A)** The use of foam-based extinguishers to put out oil or gasoline fires is described in the fourth paragraph. The paragraph concludes, “these extinguishers have the advantage of minimizing the extensive water damage caused by more traditional fire-fighting methods.” Option A restates this information.

**50. (F)** Read all five options to choose the one that is **not** an ingredient of dishpan suds. Dishpan suds are mentioned as one of several examples of soap foams in lines 40-41. The second paragraph explains that soap foams consist of soap (Option H), which is a surfactant (Option K), added to an aqueous foam formed of water (Option G) and air (Option J). Option F, “protein,” is an ingredient of whipped cream and marshmallows (lines 42-44), but not of dishpan suds.



- 51. (B)** Convert the mixed number 3.6 to its fractional equivalent,  $3\frac{6}{10}$ . Then change it to an improper fraction, which is  $\frac{36}{10}$ . When dividing by a fraction, multiply the dividend by the reciprocal of the divisor.

$$\left(\frac{36}{10}\right)\left(\frac{3}{2}\right) = \frac{(36)(3)}{(10)(2)} = \frac{54}{10} = 5\frac{4}{10} = 5.4$$

- 52. (G)**  $-2x(3y - 4z) = (-2x)(3y) - (-2x)(4z)$   
 $= -6xy + 8xz$

- 53. (A)** If Maria is 16 now, in 6 years she will be 22. Since she will then (in 6 years) be twice as old as her brother, he will be 11 (in 6 years). To find his present age, subtract 6 from 11. Thus, he is now 5 years old.

- 54. (H)** Method I: 6.44 rounds to 6.4 because the digit in the hundredths place (4) is less than 5. 6.46 rounds to 6.5 because the digit in the hundredths place (6) is 5 or greater.

$$6.4 + 6.5 = 12.9$$

Method II: Both 6.44 and 6.46 round to 6 because the number in the tenths place (4) is less than 5 for each of them.

$$6 + 6 = 12$$

To calculate by how much the results from Method I are greater than the results for Method II, you subtract:

$$12.9 - 12 = 0.9$$

- 55. (E)** In these types of questions, it is sometimes easiest to assign values to the variables to test each possibility. We know that M and T are both odd, and M is a multiple of T. So, let's assign  $T = 3$  and  $M = 5 \cdot T = 15$ .

Option A says "M + T is odd."  $15 + 3 = 18$ , which is even, so A is not true.

Option B says "MT is even."  $15 \times 3 = 45$ , which is odd, so B is not true.

Option C says "M - T is odd."  $15 - 3 = 12$ , which is even, so C is not true.

Option D says "M ÷ T is even," and Option E says "M ÷ T is odd." Because these statements are opposites, one of them must be true.  $15 \div 3 = 5$ , which is odd, so E is the correct answer.

As a shortcut, because options D and E are both division with opposite results, and only one can be true, you could test only these two options to determine which is correct.

- 56. (F)** To solve this, let  $x =$  the number of inches between the towns on the map.

First, set up a proportion, and then solve for  $x$ :

$$\frac{x \text{ inches}}{m \text{ miles}} = \frac{1 \text{ inch}}{10 \text{ miles}}$$

$$\frac{x}{m} = \frac{1}{10}$$

$$x = m \cdot \frac{1}{10} = \frac{m}{10}$$

- 57. (E)** We know that  $\frac{1}{3}$  of the 1,650 voters were born between 1950 and 1979, inclusive; therefore,  $\frac{2}{3}$  of the voters were born either before 1950 or after 1979.

$$\frac{2}{3} \times 1,650 = 1,100$$

Alternatively, you could calculate the number of voters who were born between 1950 and 1979, inclusive, and then subtract that number from the total:

$$\frac{1}{3} \times 1,650 = 550$$

$$1,650 - 550 = 1,100$$



- 58. (J)** The first letter in the code could be any of the 5 letter choices. Then the second letter in the code could be any of the 4 remaining choices. The third letter of the code could be any of the 3 remaining choices, and so on. The number of different codes Tien can make is:

$$5 \cdot 4 \cdot 3 \cdot 2 \cdot 1 = 120$$

- 59. (D)** The question states that  $PQ = 9$  cm, so we know  $x = 9$ . We can use that information to calculate the length of QR.

$$QR = \frac{2}{3}x = \frac{2}{3} \cdot 9 = 6 \text{ centimeters}$$

Add PQ and QR to get the length of PR.

$$PQ + QR = 9 + 6 = 15 \text{ centimeters}$$

- 60. (H)** First, read the column headings to find the relevant one, "Spending per Student." To calculate the median spending per student, put the values in this column in order from least to greatest:

\$7,600, \$7,600, \$8,000, \$8,400, \$10,000, \$11,200

The median is the number at the exact center of a set of values. Since there are an even number of values in the above set, find the middle two values and calculate the mean of those to get the median of the set:

$$(\$8,000 + \$8,400) \div 2 = \$8,200$$

- 61. (A)** First, round 1.095 to the nearest tenth, resulting in a value of 1.1. The question asks how much greater this rounded number is than 1.095, so you need to subtract:

$$1.1 - 1.095 = 0.005$$

- 62. (G)** First, round the elevation of each continent to the nearest thousand feet, and then, because the mode is the most frequently occurring value, look for the elevation that appears most often.

**After rounding:**

North America = 2,000

South America = 2,000

Europe = 1,000

Asia = 3,000

Africa = 2,000

Oceania = 1,000

Antarctica = 6,000

The elevation 2,000 is listed most frequently (3 times), so the mode is 2,000 feet.

- 63. (C)** The original 24-ft board is cut in half, resulting in two 12-ft pieces.

One of those 12-ft pieces is cut in half again, resulting in two 6-ft pieces.

One of the 6-ft pieces is cut into thirds, resulting in three 2-ft pieces.

The length of the longest piece is 12 feet, and the length of one of the shortest pieces is 2 feet. The difference is  $12 - 2 = 10$  feet.

- 64. (F)** Each number in the sequence is the difference between the two previous numbers. For example,  $12 - 10 = 2$ , so 2 is the third term.

To find the seventh term, subtract the sixth term from the fifth term:

$$^{-}6 - 14 = ^{-}20$$

- 65. (D)**  $|\frac{1}{16}| \cdot |16| + |^{-}16| + |16|$

$$= \left(\frac{1}{16} \cdot 16\right) + 16 + 16$$

$$= 1 + 16 + 16$$

$$= 33$$



66. (J) Bettina's height is given as 140 cm. Let her sister's height be  $x$ . Set up a proportion to calculate the sister's height, and solve for  $x$ :

$$\begin{aligned}\frac{7}{6} &= \frac{140}{x} \\ 7x &= 140(6) \\ 7x &= 840 \\ x &= 120 \text{ cm}\end{aligned}$$

The question asks "how much taller is Bettina than her sister?" Subtract to find the answer:

$$140 - 120 = 20 \text{ cm}$$

67. (B) Factorize 210 into its prime factors:

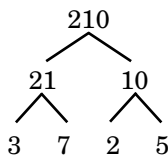

The greatest prime factor is 7.

68. (J) Because point T is at the center of the circle and point U is on the circle, TU must be a radius ( $r$ ) of the circle. We know the circumference of the circle is  $8\pi$  cm. Therefore, we can use the formula for the circumference of a circle to calculate the length of TU.

$$\begin{aligned}\text{Circumference} &= 2\pi r \\ 8\pi \text{ cm} &= 2\pi r \text{ cm} \\ 4 \text{ cm} &= r\end{aligned}$$

$$\text{Thus, } TU = 4 \text{ cm.}$$

The formula for the area of a rectangle is length times width. The length of the rectangle (12 cm) is given in the diagram, and the width of the rectangle is TU (4 cm).

$$\text{Area} = (12 \text{ cm}) \times (4 \text{ cm}) = 48 \text{ sq cm}$$

69. (D) To find the greatest common factor, determine the prime factorization of each number first:

$$\begin{aligned}459 &= 9 \times 51 \\ &= 3 \times 3 \times 3 \times 17\end{aligned}$$

$$\begin{aligned}567 &= 9 \times 63 \\ &= 9 \times 9 \times 7 \\ &= 3 \times 3 \times 3 \times 3 \times 7\end{aligned}$$

Because  $3 \times 3 \times 3$ , or 27, is the largest number that divides evenly into both 459 and 567, 27 is their greatest common factor.

70. (G) Answer this question by evaluating each statement:

In order for two shapes to be **congruent**, they need to have the same angle measures and the same side lengths. Option F says "all equilateral triangles are congruent." All equilateral triangles have the same angle measures ( $60^\circ$  for each angle), but the side lengths could be different (e.g., triangle A could have side lengths of 3 cm and triangle B could have side lengths of 7 cm). Thus, Option F is false.

By applying the same logic, Option H ("all rectangles are congruent") and Option K ("all squares are congruent") are also false. All rectangles and squares have the same angle measures ( $90^\circ$  for each angle), but the side lengths could be different from one shape to the other.

Two shapes are **similar** when they have the same angle measures and the lengths of the corresponding sides of the two shapes are proportional. Option J is false because it is possible to have two rectangles whose side lengths are not proportional.

Option G ("all equilateral triangles are similar") is the only true statement. All sides of an equilateral triangle are the same length. So, the sides of two equilateral triangles would be proportional.

71. (B) A linear relationship (or function) means that a change in temperature is proportional to a change in the number of cups sold. So, we can start with the proportion showing the relationship between the change in the number of cups sold ( $440 - 200$ ) and the change in the corresponding temperatures ( $50 - 70$ ):

$$\frac{440 - 200}{50 - 70} = \frac{240}{-20} = -12$$

Thus, for every degree the temperature rises, the vendor can plan to sell 12 fewer hot drinks.

When the temperature was  $50^\circ$ , the vendor sold 440 hot drinks. When the temperature rises by  $5^\circ$  to  $55^\circ$ , he can expect to sell  $5 \times 12 = 60$  fewer drinks than when the temperature was  $50^\circ$ . Subtract to find the total number of cups he can expect to sell at  $55^\circ$ :  $440 - 60 = 380$  cups.



- 72. (K)** The first time the bamboo blooms after 1820 is 1824 ( $1807 + 17$ ). Keep adding 17 to your answer until you get to the year 2011:  
1824, 1841, 1858, 1875, 1892, 1909, 1926, 1943, 1960, 1977, 1994, 2011

The answer is 12.

A quicker way to solve this is to find the first year the bamboo blooms within the given range of years (1824). Subtract that year from the final year (2011), and divide by 17 (the number of years between blooms):

$$\frac{2011 - 1824}{17} = 11 \text{ and } 11 + 1 = 12$$

Remember to add 1 to get 12 because both end points (1824 and 2011) need to be counted.

- 73. (E)** In this kind of problem, first simplify the numerator and the denominator separately, and then reduce the fraction to lowest terms.

Numerator:

$$(-1)^2 + (-2)^3 + (-3)^4 = (1) + (-8) + (81) = 74$$

Denominator:

$$(-1)^4 + (-2)^3 + (-3)^2 = (1) + (-8) + (9) = 2$$

Now you can reduce the fraction:

$$\frac{74}{2} = 37$$

- 74. (G)** If 70% to 80% of students own a cell phone, then 20% to 30% do **not** own a cell phone. Since we are looking for the maximum number of students who do **not** own a cell phone, calculate 30% of 900:

$$900 \times 30\% = 270 \text{ students}$$

- 75. (C)** Now:  
Seung's age =  $y$   
Jackson's age = 3 years older than Seung =  $3 + y$

Eight years ago:

$$\text{Jackson's age} = (3 + y) - 8 = y - 5$$

- 76. (G)** To find the midpoint of a line segment, add the two endpoints together and then divide the sum by two:

$$\frac{\frac{2}{5} + -2}{2} = \frac{\frac{2}{5} - \frac{10}{5}}{2} = \frac{-\frac{8}{5}}{2} = -\frac{4}{5}$$

- 77. (B)** We are given the total number of coins (48). If the number of dimes is  $x$ , then the number of nickels is  $48 - x$ . A dime is represented as \$0.10, and a nickel as \$0.05. Now we can set up the problem:

$$\$0.10x + \$0.05(48 - x) = \$3.90$$

$$\$0.10x + \$2.40 - \$0.05x = \$3.90$$

$$\$0.05x = \$1.50$$

$$x = 30$$

Thus, there are 30 dimes and 18 nickels ( $48 - 30$ ).

The question asks "how many more dimes than nickels?" Subtract to find the answer:

$$30 - 18 = 12$$

- 78. (K)** Because we know that the side of the square is equal in length to the diameter of the circle, we can set the value for both the side of the square and diameter of the circle to  $x$ .

$$\text{Perimeter of the square} = 4 \times \text{side length} = 4x$$

$$\text{Circumference of the circle} = \text{diameter} \times \pi = x\pi$$

Use these values to determine the ratio of the perimeter of the square to the circumference of the circle:

$$\frac{4x}{x\pi} = \frac{4}{\pi}$$

- 79. (B)** To calculate the fraction, divide the down payment by the sale price:

$$\frac{\$400}{\$5,000} = \frac{4}{50} = \frac{8}{100} = 0.08$$



- 80. (J)** First, calculate the volume of the stack using the formula length  $\times$  width  $\times$  height:

$$5 \text{ in.} \times 10 \text{ in.} \times 20 \text{ in.} = 1,000 \text{ cubic inches}$$

To determine the weight of the stack, multiply the number of cubic inches by the weight per cubic inch:

$$1,000 \times 0.035 = 35 \text{ ounces}$$

Notice that the number of sheets of plastic is given (50), but is not relevant to the solution.

- 81. (B)** First, calculate the area of the circular region using the given radius of 3 feet:

$$\begin{aligned} \text{Area} &= \pi r^2 = (3)^2 \pi = 9\pi = 9(3.14) \\ &= 28.26 \text{ square feet} \end{aligned}$$

Notice that  $\pi$  was rounded to 3.14 because the question asks for an approximation.

Subtract the area that the paint can cover (25 sq ft) from the area of the region to get the answer:

$$28.26 - 25 = 3.26 = 3.3 \text{ sq ft}$$

- 82. (H)** Let  $x$  = Gloria's sales for this period. Set up an equation using her commission for this period (\$12,000) and the commission rate (15%):

$$\$12,000 = 0.15x$$

$$\frac{\$12,000}{0.15} = x$$

$$\$80,000 = x$$

- 83. (A)** The solution to this problem requires finding the pattern. The pattern for  $x$  is easy: the numbers in  $x$  always change by 1. The pattern for  $y$  is tougher to see. Since  $y$  is a sum of two terms (an  $a$  term and a negative  $b$  term), we can determine the pattern for each of these terms individually, as follows:

term	term
$-a$	$-\frac{b}{2}$
0	$-\frac{b}{3}$
$a$	$-\frac{b}{4}$
$2a$	$-\frac{b}{5}$
The $a$ term changes by adding $a$ to the previous value.	The $b$ term changes by increasing the denominator by 1.

We want to know the value of  $y$  when  $x = 0$ , so we need to find the value of  $y$  that comes **before** the first  $y$  ( $-a - \frac{b}{2}$ ) in the table. To do this, we subtract  $a$  from the  $a$  term and subtract 1 from the denominator of the  $b$  term in the first  $y$ . Thus, when  $x = 0$ ,  $y = (-a - a) - \frac{b}{2 - 1} = -2a - b$

- 84. (K)** Daquan sold  $x$  hot dogs. Let  $c$  represent the number of hot dogs that Caitlyn sold:

$$c + x = 5x - 2$$

$$c = 4x - 2$$

- 85. (B)** For a house that sells for \$199,000, the real estate agent charges a commission of 3%.

$$\$199,000(0.03) = \$5,970$$

For a house that sells for \$201,000, the real estate agent charges a commission of 2.5%.

$$\$201,000(0.025) = \$5,025$$

Subtract to find how much more the agent makes on the \$199,000 sale:

$$\$5,970 - \$5,025 = \$945$$





- 86. (J)** From the given equation,  $r$  must be a multiple of 3, 4, and 10. To find the least possible value of  $r$ , find the least common multiple of 3, 4, and 10.

All multiples of 10 must end in zero (10, 20, ...), so we just need to look at the multiples of 3 and 4 that also end in zero:

Multiples of 3: 30, 60, 90, ...  
Multiples of 4: 20, 40, 60, 80, ...

Since 60 is the first multiple that appears in both lists above, 60 is the least common multiple of 3, 4, and 10. Thus, the least possible value of  $r$  is 60.

- 87. (C)** To solve this problem, find the number of multiples of 2 between 4 and 81. Then, find the number of multiples of 7 between 4 and 81:

**Multiples of 2** (4, 6, 8, ..., 80):

$$\frac{80 - 4}{2} = 38, \text{ but we need to add 1 because}$$

both ends are counted, so  $38 + 1 = 39$

**Multiples of 7** (7, 14, 21, 28, ..., 77):

$$\frac{81 - 4}{7} = 11$$

Next, we need to determine how many of the multiples of 7 are even, because they will have been counted twice (once in the list of the multiples of 2 and again in the list of the multiples of 7). The multiples of 7 alternate odd and even, which means approximately half of them are odd and half are even. (Because there are 11 values, 6 must be either even or odd, and 5 must be the other.) The first and last multiple of 7 in this case are both odd, so that means 6 are odd and 5 are even (i.e., multiples of 2).

To find the total number of integers that are multiples of 2, multiples of 7, or both, add the count of the multiples of 2 and the multiples of 7, and subtract the number of integers that appear in both lists:

$$\begin{aligned} &(\text{multiples of 2}) + (\text{multiples of 7}) - (\text{both}) \\ &= 39 + 11 - 5 \\ &= 45 \end{aligned}$$

- 88. (K)** Solve for  $s$ :

$$\frac{3t - s}{4} = 8s$$

$$3t - s = 32s$$

$$3t = 33s$$

$$\frac{t}{11} = s$$

- 89. (A)** The values of  $r$  and  $s$  are not known, but the information given ( $r \neq s$  and  $r \neq -s$ ) rules out the possibility that the denominator of either fraction could be zero, which would result in an undefined expression. Simplify the expression by canceling out  $r + s$  and  $r - s$ . Only  $rs$  remains.

- 90. (H)** Complete the calculations for the quantity under the square root sign:

$$\sqrt{6^2 + 7^2}$$

$$\sqrt{36 + 49}$$

$$\sqrt{85}$$

85 falls between the squares of 9 and 10, which are 81 and 100, respectively.

$$81 < 85 < 100$$

$$9^2 < 85 < 10^2$$

- 91. (D)** Use the formula for the area of a triangle to solve for BE:

$$\text{Area} = \frac{1}{2} (\text{base}) (\text{height})$$

$$25 = \frac{1}{2} (5) (\text{BE})$$

$$25 = 2.5 (\text{BE})$$

$$10 = \text{BE}$$

The area of a parallelogram is base  $\times$  height. The base of ABCD is 50 cm. BE is perpendicular to AED, so the height of the parallelogram is 10 cm.

$$\text{Area} = (50 \text{ cm})(10 \text{ cm})$$

$$\text{Area} = 500 \text{ sq cm}$$



- 92. (J)** Since there are 60 minutes in 1 hour, multiply 2.35 by 60 to convert it to minutes:

$$2.35 \times 60 = 141 \text{ minutes}$$

- 93. (E)** Because we know that 100% of the group indicated whether or not they were in favor of Proposition A, Proposition B, or both, we can add the percentages given in the question:

$$\begin{aligned} 65\% \text{ (in favor of Proposition A)} + 72\% \text{ (in favor of} \\ \text{Proposition B)} + 3\% \text{ (in favor of neither)} \\ = 140\% \text{ total} \end{aligned}$$

The amount over 100% is the percentage of people who indicated they were in favor of both Proposition A and Proposition B and were therefore counted twice. So, the answer is  $140\% - 100\% = 40\%$ .

- 94. (G)** For any one triangular face of the pyramid, we know the base (8 cm) and height (6 cm).

$$\begin{aligned} \text{Area of one triangle} &= \frac{1}{2} \times \text{base} \times \text{height} \\ &= \frac{1}{2} \times (8 \text{ cm}) \times (6 \text{ cm}) \\ &= 24 \text{ sq cm} \end{aligned}$$

All four of the triangular faces have the same area, so the total surface area of the pyramid is:

$$4 \times 24 = 96 \text{ sq cm}$$

- 95. (D)** The distance from A to B is  $\frac{1}{6}$  of a revolution. The arrow will point to B for the eleventh time after  $10\frac{1}{6}$  revolutions. The rate of the arrow is:

$$5 \frac{\text{rev}}{\text{min}} = 5 \frac{\text{rev}}{\text{min}} \times \frac{1 \text{ min}}{60 \text{ sec}} = \frac{1 \text{ rev}}{12 \text{ sec}}$$

Use the formula for rate  $\times$  time = distance. Let  $x$  represent the number of seconds.

$$\begin{aligned} x \text{ sec} \left( \frac{1 \text{ rev}}{12 \text{ sec}} \right) &= 10\frac{1}{6} \text{ revolutions} \\ \frac{x}{12} &= \frac{61}{6} \\ x &= \frac{(61)(12)}{6} = (61)(2) \\ &= 122 \text{ sec} \end{aligned}$$

- 96. (F)** First, combine like terms, and then solve for  $k$ :

$$\begin{aligned} (3m + 2n) - (2m - 3n) + k &= 0 \\ 3m + 2n - 2m + 3n + k &= 0 \\ m + 5n + k &= 0 \\ k &= -m - 5n \end{aligned}$$

- 97. (D)** Each even digit in the right column is twice the position (left column) minus 2.

$$\text{For example, in position 1: } 2(1) - 2 = 0$$

$$\text{In position 2: } 2(2) - 2 = 2$$

$$\text{In position 3: } 2(3) - 2 = 4$$

$$\text{So, for position 500: } 2(500) - 2 = 1,000 - 2 = 998$$

- 98. (G)** The answers are given in cubic yards, so the dimensions of the foam must be calculated in yards. The width and length of the rectangular region are 10 yards and 50 yards, respectively. The depth (height) of the foam over the rectangular region is 9 inches, which is  $\frac{1}{4}$  yard (1 yard = 36 inches).

$$\begin{aligned} \text{Volume} &= (\text{length})(\text{width})(\text{height}) \\ &= (50)(10)\frac{1}{4} \\ &= \frac{500}{4} \text{ cu yd} \\ &= 125 \text{ cu yd} \end{aligned}$$



99. (D) Whole numbers are the “counting” numbers: 1, 2, 3, 4, etc. Test each value of  $x$  in the given expression:

$$x = 5 \quad \frac{5 + 7}{5 - 7} = \frac{12}{-2} = -6$$

This **cannot** be a value of  $x$  because  $-6$  is not a whole number.

$$x = 6 \quad \frac{6 + 7}{6 - 7} = \frac{13}{-1} = -13$$

This **cannot** be a value of  $x$  because  $-13$  is not a whole number.

$$x = 7 \quad \frac{7 + 7}{7 - 7} = \frac{14}{0} = \text{undefined}$$

This **cannot** be a value of  $x$  because the expression is undefined.

$$x = 8 \quad \frac{8 + 7}{8 - 7} = \frac{15}{1} = 15$$

This **can** be a value of  $x$  because 15 is a whole number.

$$x = 9 \quad \frac{9 + 7}{9 - 7} = \frac{16}{2} = 8$$

This **can** be a value of  $x$  because 8 is a whole number.

The question asks how many of the listed numbers **cannot** be a value of  $x$ , so the answer is 3.

100. (J) The range is the difference between the highest score and the lowest score.

First, calculate the highest score for each section. Use the sum of the lowest score and the range to get the highest score.

$$\text{Section I: } 65 + 28 = 93$$

$$\text{Section II: } 62 + 25 = 87$$

$$\text{Section III: } 67 + 22 = 89$$

To find the **overall** range of all the scores, take the highest of all the scores (93) and subtract the lowest of all the scores (62). The answer is 31.

### Answer Key for Sample Form B

Paragraph 1 T Q U R S	11. C	21. A	31. A	41. B	51. B	61. A	71. B	81. B	91. D
Paragraph 2 R Q T U S	12. J	22. G	32. J	42. G	52. G	62. G	72. K	82. H	92. J
Paragraph 3 S R U Q T	13. C	23. E	33. C	43. A	53. A	63. C	73. E	83. A	93. E
Paragraph 4 T R U Q S	14. J	24. G	34. H	44. H	54. H	64. F	74. G	84. K	94. G
Paragraph 5 U Q S R T	15. B	25. E	35. E	45. E	55. E	65. D	75. C	85. B	95. D
	16. F	26. H	36. K	46. H	56. F	66. J	76. G	86. J	96. F
	17. E	27. E	37. D	47. B	57. E	67. B	77. B	87. C	97. D
	18. K	28. G	38. F	48. F	58. J	68. J	78. K	88. K	98. G
	19. E	29. C	39. D	49. A	59. D	69. D	79. B	89. A	99. D
	20. F	30. F	40. K	50. F	60. H	70. G	80. J	90. H	100. J

**DIRECTIONS:** This section provides sample mathematics problems for the Grade 9 test forms. These problems are based on material included in the New York City curriculum for Grade 8. (The Grade 8 problems on sample forms A and B cover mathematics material through Grade 7.) General directions for how to answer math questions are located on pages 48 and 86. There is no sample answer sheet for this section; mark your answers directly on this page or on a separate piece of paper.

1. If  $\frac{x}{3} = \frac{3x - 15}{4}$ , what is the value of  $x$ ?
- A. 9
- B.  $\frac{15}{2}$
- C.  $\frac{45}{13}$
- D. 3
- E. -9

2.

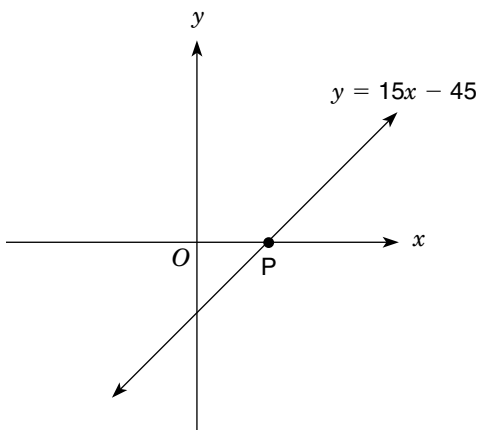

The line defined by the equation  $y = 15x - 45$  intercepts the  $x$ -axis at point P as shown above. What are the coordinates of point P?

- F. (45, 0)
- G. (3, 0)
- H. (-3, 0)
- J. (0, -3)
- K. (0, -45)

3. How many different ways can a team of 2 men and 2 women be formed if there are 4 men and 5 women from which to select?
- A. 4
- B. 6
- C. 16
- D. 60
- E. 240

4.

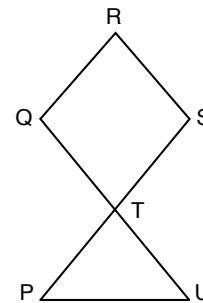

In the figure above,  $\angle QTS$  is congruent to  $\angle QRS$ . Point T lies at the intersection of line segments  $\overline{QU}$  and  $\overline{PS}$ . Which of the following angles must also be congruent to  $\angle QRS$ ?

- F.  $\angle RST$
- G.  $\angle PTQ$
- H.  $\angle TUP$
- J.  $\angle TPU$
- K.  $\angle PTU$

5. If  $(4^3)(8^2) = 2^x$ , what is the value of  $x$ ?
- A. 12
- B. 10
- C. 7
- D. 6
- E. 5

6. If  $N = 1.\overline{25}$ , what is the value of  $N$  expressed as a fraction?

F.  $\frac{5}{4}$

G.  $\frac{124}{99}$

H.  $\frac{113}{90}$

J.  $\frac{125}{99}$

K.  $\frac{14}{11}$

7. If 1 liter is approximately equal to 1.06 quarts and 32 ounces equals 1 quart, how many 20-ounce containers of soda can be **completely** filled by a 2-liter container of soda?

A. 2

B. 3

C. 4

D. 5

E. 6

8.

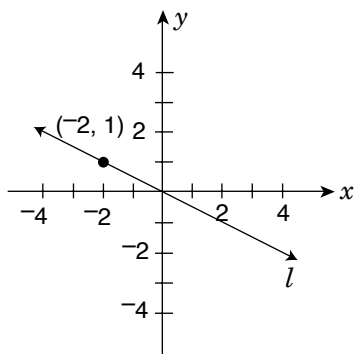

In the figure above, line  $l$  passes through the origin. Which equation below describes line  $l$ ?

F.  $y = 2x$

G.  $y = -2x$

H.  $y = x$

J.  $y = \frac{1}{2}x$

K.  $y = -\frac{1}{2}x$

9. What is the simplified form of  $\frac{6(2x^2 - 4x)}{3x}$  if  $x \neq 0$ ?

A.  $4x - 4$

B.  $4x^2 - \frac{8}{3}$

C.  $4x - 8$

D.  $4x^2 - 8$

E.  $4x^2 - 8x$

10. The translation of point  $P(3, 5)$  to  $P'(5, -3)$  is equivalent to rotating point  $P$  by which of the following clockwise rotations about the origin?

F.  $45^\circ$

G.  $90^\circ$

H.  $135^\circ$

J.  $180^\circ$

K.  $225^\circ$

11. What is the greatest integer  $n$  that satisfies the inequality  $5 - n \geq 3n - 4$ ?

A. 1

B. 2

C.  $2\frac{1}{4}$

D. 3

E. 4

12. The volume of a cube is 729 cubic feet. What is the length, in **inches**, of one side of this cube?

F.  $\frac{3}{4}$  in.

G. 9 in.

H. 108 in.

J. 243 in.

K. 2,916 in.

13.

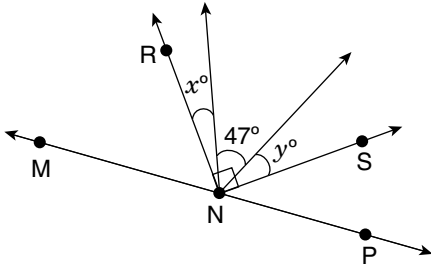

In the figure above, point  $N$  lies on straight line  $\overleftrightarrow{MNP}$ , and  $\angle RNS$  is a right angle. What is the value of  $y$  in terms of  $x$ ?

- A.  $43 - x$
- B.  $x - 43$
- C.  $133 - x$
- D.  $x - 133$
- E.  $x$

14. A property is valued at \$300,000 today. If this represents a 150% increase in value over its value 10 years ago, what was the value of this property 10 years ago?

- F. \$120,000
- G. \$150,000
- H. \$200,000
- J. \$275,000
- K. \$450,000

15.

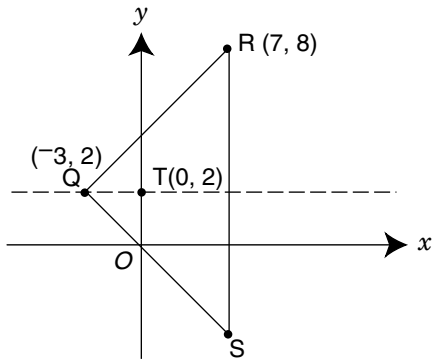

The dashed line is the line of symmetry for triangle  $QRS$ . What are the coordinates of point  $S$ ?

- A.  $(-7, -8)$
- B.  $(7, -8)$
- C.  $(7, -4)$
- D.  $(-7, -4)$
- E.  $(7, 8)$

16.

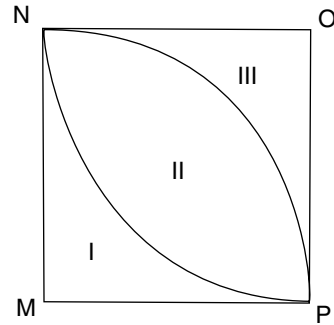

In the figure above,  $MNOP$  is a square with sides of length 20. Each arc inside  $MNOP$  is  $\frac{1}{4}$  of the circumference of a circle with either  $M$  or  $O$  as its center. What is the area of the region labeled II? Express your answer in terms of  $\pi$ .

- F.  $50\pi$
- G.  $100\pi$
- H.  $200\pi - 100$
- J.  $200\pi - 400$
- K.  $800\pi - 400$

17.

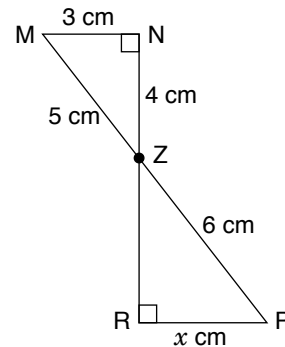

In the figure above, all lines are straight.  $\overline{MP}$  and  $\overline{RN}$  intersect at point  $Z$ . What is the value of  $x$ ?

- A. 3
- B.  $3\frac{3}{5}$
- C. 4
- D.  $4\frac{4}{5}$
- E. 5



1. (A) First, cross-multiply to eliminate the denominators, and then solve for  $x$ :

$$\begin{aligned}4x &= 3(3x - 15) \\4x &= 9x - 45 \\-5x &= -45 \\x &= 9\end{aligned}$$

2. (G) Since P is on the  $x$ -axis, we know its  $y$ -value must equal 0. Use that in the equation to solve for  $x$ :

$$\begin{aligned}y &= 15x - 45 \\0 &= 15x - 45 \\45 &= 15x \\3 &= x\end{aligned}$$

So, the coordinates for P are (3, 0).

3. (D) In this case, the order in which you select the people is not important, so you cannot simply use the counting principle.

To solve this problem, first calculate the number of possible combinations for each gender.

**Select 2 men from 4 men** (a, b, c, d):

ab, ac, ad, bc, bd, cd

So, there are 6 ways to select 2 men from a group of 4 men.

**Select 2 women from 5 women** (v, w, x, y, z):

vw, vx, vy, vz, wx, wy, wz, xy, xz, yz

So, there are 10 ways to select 2 women from a group of 5 women.

The selection of one gender is independent of the selection of the other. Multiply the number of possible combinations for each gender:  
 $6 \times 10 = 60$  different combinations.

4. (K)  $\angle QTS$  and  $\angle PTU$  are vertical angles, so they are congruent. Since  $\angle QRS$  is congruent to  $\angle QTS$ , then  $\angle QRS$  is also congruent to  $\angle PTU$ .

5. (A) Begin by finding a common base for each term. In this case, the common base is 2.

$$\begin{aligned}4 &= 2^2 \\8 &= 2^3 \\(4^3)(8^2) &= (2^2)^3(2^3)^2 \\&= (2^6)(2^6) \\&= 2^{12} \\ \text{So, } x &= 12.\end{aligned}$$

Alternatively, you could multiply the left side of the equation and then factor it:

$$\begin{aligned}(4^3)(8^2) &= (4 \times 4 \times 4)(8 \times 8) \\&= (2 \times 2 \times 2 \times 2 \times 2 \times 2)(2 \times 2 \times 2 \times 2 \times 2 \times 2) \\&= 2^{12}\end{aligned}$$

6. (G) Start with the original equation:  $N = 1.\overline{25}$

Set up a second equation in which you multiply both sides of the original equation by a multiple of 10. You multiply by 10 for each digit in the repeating sequence. In this case, there are two digits, so you multiply by 10 twice, i.e., 100.

$$\begin{aligned}100N &= 100(1.\overline{25}) \\100N &= 125.\overline{25}\end{aligned}$$

Now, subtract the two equations, then solve for  $N$ :

$$\begin{array}{r}100N = 125.\overline{25} \\-N = -1.\overline{25} \\ \hline 99N = 124 \\ N = \frac{124}{99}\end{array}$$

A shortcut is to recall that single-digit fractions with 9 as the denominator repeat, for example:

$$\frac{1}{9} = 0.\overline{1}, \quad \frac{2}{9} = 0.\overline{2}$$

This can be extended to two-digit fractions with 99 as the denominator, for example:

$$\frac{10}{99} = 0.\overline{10}, \quad \frac{20}{99} = 0.\overline{20}$$

In this case,  $1.\overline{25} = 1\frac{25}{99} = \frac{124}{99}$



7. (B) Begin by converting from liters to quarts, and then from quarts to ounces. We know that 1 liter = 1.06 quarts, and 1 quart = 32 ounces, so:

$$1 \text{ liter} = 1.06 \times 32 = 33.92 \text{ ounces}$$

We want to divide a 2-liter container of soda into 20-ounce containers.

$$2 \text{ liters} = 2 \times 33.92 = 67.84 \text{ ounces}$$

$$67.84 \div 20 = 3.392 \text{ containers}$$

The number 3.392 is greater than 3 but less than 4, so the answer is 3 full containers.

8. (K) The equation of a line is  $y = mx + b$ , where  $m$  is the slope and  $b$  is the  $y$ -intercept. Since the line passes through the origin,  $b = 0$ , so we only need to find the slope. Because we are given the point  $(-2, 1)$  and the origin  $(0, 0)$ , we can use the slope formula:

$$m = \frac{1 - 0}{-2 - 0} = -\frac{1}{2}$$

Now, substitute the values for  $m$  and  $b$  in the equation:

$$y = mx + b$$

$$y = -\frac{1}{2}x + 0$$

$$y = -\frac{1}{2}x$$

9. (C) There are many ways to simplify this expression, but one way to begin is by simplifying the polynomial in the numerator:

$$\begin{aligned} & \frac{6(2x^2 - 4x)}{3x} \\ &= \frac{12x^2 - 24x}{3x} \end{aligned}$$

Divide the numerator and denominator by  $3x$ :

$$= 4x - 8$$

10. (G) If the coordinates of a point labeled  $R$  are  $(a, b)$ , then a  $90^\circ$  **counterclockwise** rotation about the origin would make the coordinates of point  $R'$   $(-b, a)$ . A  $90^\circ$  **clockwise** rotation about the origin would make the coordinates of  $R'$   $(b, -a)$ .

In the question,  $P$  is  $(3, 5)$  and  $P'$  is  $(5, -3)$ .

Using the rule stated above,  $P'$  is the image after point  $P$  is rotated  $90^\circ$  clockwise.

Alternatively, it may help to make a sketch of this problem. Place the two points on the coordinate grid: Point  $P$  is in the first quadrant, and point  $P'$  is in the fourth quadrant. Draw a line from each point to the origin. The angle formed at the origin should resemble a right angle, which is option G ( $90^\circ$ ).

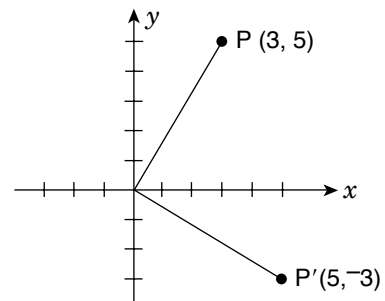

11. (B) First, simplify the inequality to get  $n$  on one side:

$$5 - n \geq 3n - 4$$

$$9 \geq 4n$$

$$\frac{9}{4} \geq n$$

$$2\frac{1}{4} \geq n$$

Since  $n$  is less than or equal to  $2\frac{1}{4}$ , the greatest integer value of  $n$  is 2.





- 12. (H)** The volume of the cube is 729 cubic feet, so one side of that cube is  $\sqrt[3]{729} = 9$  feet. The question asks for the length of an edge in inches.  
 $9 \text{ feet} \times 12 = 108 \text{ inches}$

- 13. (A)** Angle RNS is a right angle ( $90^\circ$ ). From the figure, we see that three smaller angles ( $x^\circ$ ,  $y^\circ$ , and  $47^\circ$ ) combine to make RNS:

$$\begin{aligned} x + y + 47 &= 90 \\ x + y &= 43 \\ y &= 43 - x \end{aligned}$$

- 14. (F)** A common mistake on this type of problem is to treat a 150% increase as 1.5 times the original value. However, a 150% increase means adding 150% to the original value. If the original value is  $x$ , then  $x + 150\%$  of  $x = x + 1.5x = 2.5x$ .

The present value is 2.5 times greater than the original value:

$$\begin{aligned} \$300,000 &= 2.5x \\ \$120,000 &= x \end{aligned}$$

- 15. (C)** Because QRS is a triangle, and the dashed line is a line of symmetry, the dashed line divides the triangle exactly in half and crosses side RS at its midpoint (7, 2).

To find the  $y$ -coordinate of S, note that the  $y$ -coordinate for R is 8 and the dashed line is at  $y = 2$ . The vertical distance between R and the line of symmetry is  $8 - 2 = 6$ . Subtract 6 from the  $y$ -value for the line of symmetry to find the  $y$ -coordinate of S:  $2 - 6 = -4$ .

To find the  $x$ -coordinate of S, remember that RS must be a vertical line segment. Thus, the  $x$ -coordinate of S must be the same as the  $x$ -coordinate of R, which is 7.

So, the coordinates for S are (7, -4).

- 16. (J)** First, recognize that O and M represent the centers of the two circles.  $\overline{OP}$  and  $\overline{MP}$  are each a radius for one of the circles, and are given as length 20. Use the formula for the area of a circle to find the area of one-fourth of each circle:

$$\frac{1}{4}(20^2\pi) = 100\pi$$

The areas II + III and I + II each represent  $\frac{1}{4}$  of a circle. So,  $\text{II} + \text{III} = 100\pi$  and  $\text{I} + \text{II} = 100\pi$ .

The area of square MNOP ( $20 \times 20 = 400$ ) is equivalent to I + II + III. Use the following formula to determine the area of region II:

Area of the square = (area of quarter circle M) + (area of quarter circle O) - (overlapping area)

$$\text{I} + \text{II} + \text{III} = (\text{I} + \text{II}) + (\text{II} + \text{III}) - \text{II}$$

$$400 = (100\pi) + (100\pi) - \text{II}$$

$$400 = 200\pi - \text{II}$$

$$\text{II} = 200\pi - 400$$

- 17. (B)** Each triangle is a right triangle, and the angles formed at point Z are congruent because they are vertical angles. Thus, the two triangles are similar by definition. Set up the following proportion between similar sides to find  $x$ :

$$\frac{5}{3} = \frac{6}{x}$$

$$5x = 18$$

$$x = \frac{18}{5} = 3\frac{3}{5}$$

### Answer Key for Grade 9 Mathematics

1. A	6. G	11. B	16. J
2. G	7. B	12. H	17. B
3. D	8. K	13. A	
4. K	9. C	14. F	
5. A	10. G	15. C	



For more information, call 311 or visit [www.nyc.gov/schools](http://www.nyc.gov/schools)  
MICHAEL R. BLOOMBERG, MAYOR DENNIS M. WALCOTT, CHANCELLOR